

Makin' Wheel Loader User Guide

Version 2.33



MAKIN' 3D
MACHINE CONTROL

Copyright and disclaimer

All rights reserved. No parts of this manual may be reproduced in any form without the express written permission of Makin AS (Makin). Makin makes no warranties, express or implied, with respect to this document or its contents. In addition, the contents of the document are subject to change without prior notice. Every precaution has been taken in the preparation of this manual. Nevertheless, Makin assumes no responsibility for errors or omissions or any damages resulting from the use of the information contained.

Copyright © 2019-2025 by Makin AS.

Contact the manufacturer:

Makin AS
Vognvegen 23
2072 Dal
NORGE

www.Makin3D.com

E-mail: info@Makin3D.com

Org. no. 920 323 650

Table of contents

1. Introduction	8
1.1. Congratulations on your new product	8
1.2. Maintenance	8
1.3. Storage	8
1.4. Cleaning	8
2. Responsibility	9
2.1. Installation	9
2.2. Limitations	9
2.3. End-user license agreement	10
2.4. Warranty disclaimer	10
2.5. Software update	10
3. Product overview	11
3.1. Hardware Wheel Loader	11
3.2. Tablet buttons and light indicators (Panasonic FZ-A3)	12
3.3. Software	13
3.3.1. How to turn the system on	13
3.3.2. Elements of the work screen	13
3.3.3. Touch gestures	15
3.3.4. Symbols in the top bar	16
3.3.5. Quick keys on work screen	17
Main menu	18
4. Project	19
4.1. Open or create a project	19
4.1.1. Create a secret project	21
4.2. Transfer files	23
4.2.1. Import to project	24
4.2.2. Export as-built	30
4.3. Supported file types	33
4.3.1. Project filter	33
4.4. References	36
4.4.1. Folders	38
4.4.2. Visible reference	40
4.4.3. Side reference	41
4.4.4. Height reference	41

4.4.5. Alert reference	41
4.4.6. As-built data	42
4.4.7. Lock Reference (line, point, or surface)	43
4.4.8. Dynamic 2D files	45
4.4.9. Copy Point	46
4.4.10. Stakeout	47
4.4.11. Create point from coordinate	54
4.4.12. Create line from points	56
4.4.13. Create profile along lines	57
4.4.14. Edit Line	59
4.5. Infield Design	62
4.5.1. Points and lines in Infield Design	62
4.5.2. Info box for line	64
4.5.3. Create a boundary	64
4.5.4. Calculate volume	66
4.5.5. Infield Design report	68
4.5.6. Exiting Infield Design	69
4.6. Geodetic systems	70
4.7. Extend surface	70
4.8. Plane	72
4.9. Temporary profile	73
4.10. Project offset	74
4.11. Change offset	76
5. Display	78
5.1. Labels	79
5.2. Screen indicators	80
5.3. Use file color	81
5.4. Show maps	82
5.5. Show other systems	83
5.6. Show textures	84
5.7. Tool point coordinates	85
5.8. Machine speed	86
5.9. Auto hide quick keys	86
5.10. Reverse quick keys	87
5.11. Transparent surfaces	88
5.12. Dark theme	89

5.13. Wireframe	90
5.14. View settings	90
5.15. Change screen	92
6. Settings	93
6.1. Tolerances	93
6.1.1. Height tolerances	94
6.1.2. Side tolerances	98
6.1.3. Alert tolerances	100
6.2. Measure time	102
6.2.1. Measurement time	103
6.2.2. Delay time	104
6.3. Language	105
6.4. Length unit	105
6.5. Angle unit	106
6.6. Sound Volume	106
6.7. Area selection	107
6.8. Leveling meter	108
7. Logging (As-built)	110
7.1. Log Point	111
7.2. Log Line	114
7.2.1. Log a new line from an existing line	117
7.3. Swift between logging points and lines	121
7.4. Own objects	122
7.5. Log offset	124
7.5.1. Edit a log offset	127
7.6. Object information and attributes	129
7.7. Sort as-built data	131
8. GNSS	133
8.1. Correction source	133
8.1.1. Radio (UHF)	135
8.1.2. NTRIP	139
9. Bucket	142
9.1. Cutting Edge	143
9.2. Auto-Corner	144
10. Chat	145
11. Status	146

12. Calibration	148
12.1. Bucket calibration	148
12.1.1. Tools required	148
12.2. Bucket calibration menu	148
12.2.1. Bucket name	150
12.2.2. Blade wear front	151
12.2.3. Blade wear back	151
12.2.4. Flat angle	152
12.2.5. Blade offset back	153
12.2.6. Depth	153
12.2.7. Width	154
12.2.8. Mount height	154
12.2.9. Height	155
12.2.10. Coupler/Tilt	156
12.3. Check the calibration of your wheel loader	157
12.4. Calibration backup	157
12.4.1. Snapshots	157
12.4.2. Manual backups	158
12.4.3. Select backup file	160
13. Troubleshooting	161
14. Appendix	162
14.1. Software updates	162
14.2. GNSS limitations	164
14.3. Frequency	165
14.4. Compliance information	166
14.5. Tablet connections	167
14.5.1. Tablet Panasonic FZ-A3 connections	167
14.5.2. Tablet Panasonic FZ-A2 connections	168
14.6. Docking station connections	169
14.7. Tablet set-up	170
14.7.1. Tablet buttons and light indicators (Panasonic FZ-A2)	170
14.7.2. Programming the physical tablet buttons (Panasonic FZ)	171
14.8. Interface Box (IB-1)	173
14.9. Demo mode	174
14.10. Xbox controller	176

1. Introduction

1.1. Congratulations on your new product

You are now ready to work more efficiently and keep the precision at an optimum level. Besides that, you will be more eco-friendly by doing the same amount of work in less time.

The system is designed to show you the information you need on the screen with the greatest accuracy.

At the construction site, you are the expert - Makin' 3D is the best work companion you can get.

We at Team Makin wish you all the best with the use of your new system.

1.2. Maintenance

It is recommended to check the system's accuracy regularly. We recommend that the operator of the machine frequently checks the positioning against a known point on every job site. See Chapter *12.3: Check the calibration of your wheel loader.*

1.3. Storage

Keep the equipment safe when it's not installed in the machine. The use of a protective case is recommended if the tablet and antennas are removed from the machine to secure the devices from external stresses such as knocks and bumps.

1.4. Cleaning

The equipment must be cleaned regularly to ensure full functionality over time.

Cleaning is done by blowing to remove dust, you can also choose to use a damp cloth to wipe the tablet.

Under no circumstances should the equipment be high-pressure washed - neither inside nor outside the engine compartment.

2. Responsibility

2.1. Installation

All installation and main calibration of the system must be carried out by Makin approved technical personnel. Failure caused by unauthorized installation or repair could cause a void of warranty.

It is important to follow the machine manufacturer's instructions for installing the Makin machine control system to avoid violating any machine supplier's warranty regulations.

The user is responsible for using the product in accordance with the given instructions. The user is also responsible for ensuring that the reference models used are correct and that the bucket is properly calibrated and controlled.

Broken cables on the system may cause short circuits, system errors, and defective components. Ensure that no cables have external damage; damage must be repaired immediately before further use.

Errors in measurement results may occur if the equipment has been subjected to impact, abuse, modification, or transport damage. Control of the system after such events is important to ensure an optimum result.

Warranty: For further details, visit www.Makin3D.com for more information.

2.2. Limitations

The product is intended as a control tool, and any use beyond this is not permitted. The supplier or manufacturer cannot be held responsible for any use that goes beyond the given limits.

2.3. End-user license agreement

License: The system is preloaded with software, which can also be downloaded with permission from Makin. The software is protected by copyright and other laws. The use of the software is governed by the license agreement entered into with the Makin' 3D system when purchasing the product.

For further legal terms and conditions, including but not limited to the applicable End User License Agreement between you and Makin, we refer you to visit Makin's website, www.Makin3D.com.

2.4. Warranty disclaimer

Makin provides this documentation without warranty, term, or condition of any kind, either implied or expressed, including, but not limited to, the implied warranties, terms, or conditions of merchantability, satisfactory quality, and fitness for a particular purpose.

Makin, its employees, and agents will not be responsible for any loss, however arising, from the use of, or reliance on this information.

For further legal terms and conditions, including but not limited to the applicable End User License Agreement between you and Makin, we refer you to visit Makin's website, www.Makin3D.com.

2.5. Software update

Software will be automatically and frequently updated, and users will get a notification on the screen. Software updates require a valid maintenance license. To start downloading an updated software version, users will be asked to agree before the download starts.

3. Product overview

3.1. Hardware Wheel Loader

Hardware overview

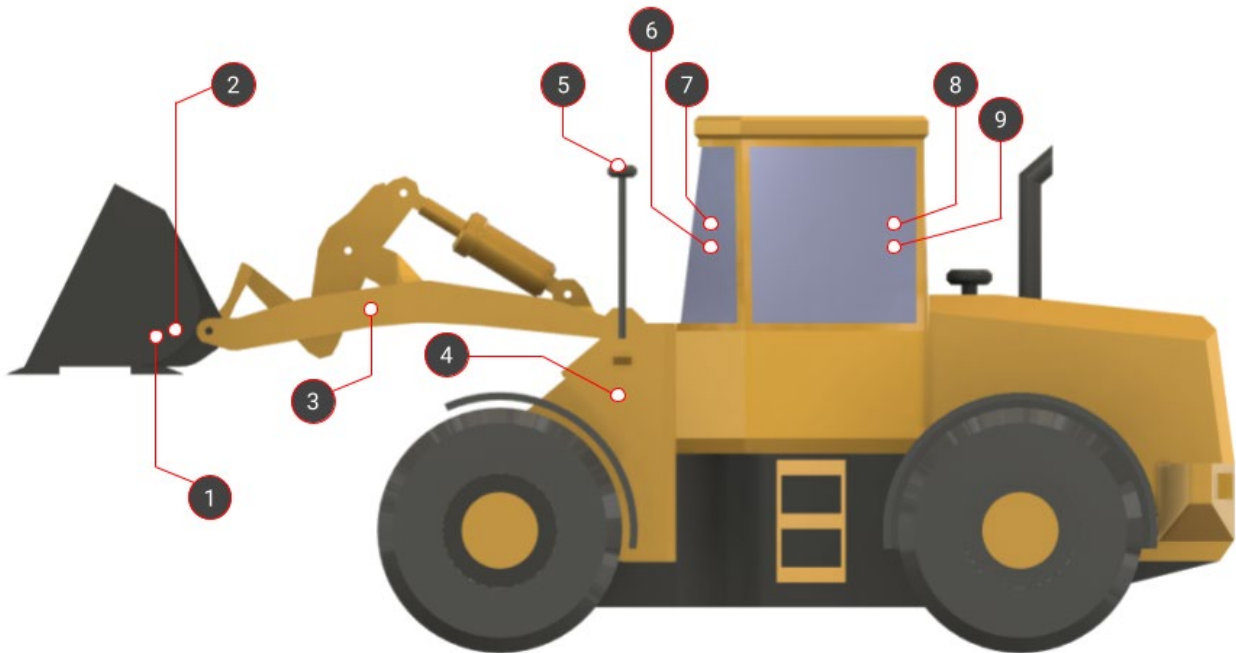

1. Bucket sensor

2. Tilt sensor (Optional)

3. Boom sensor

4. Body sensor

5. GNSS antenna

6. Tablet w. machine control software

7. Docking station for the tablet

8. GNSS receiver

9. Interface Box for system power and data communication

3.2. Tablet buttons and light indicators (Panasonic FZ-A3)



1. On/Off button

2. Volume up

3. Volume down

4. Quick access to tablet's menu

5. Not in use. The button can be programmed (more info below).

6. Not in use. The button can be programmed (more info below).

Additionally, screenshots can be taken by pressing the **'On/Off button'** and **'Volume down'** (simultaneously holding down buttons 1 and 3 for about two seconds). This can be useful in the unfortunate case where assistance is required. Find the screenshots via the **'Photos'** app.

3.3. Software

3.3.1. How to turn the system on

- 1) Turn on your Makin' 3D system by pressing the on/off button on the tablet. Android will start up and present the 'Lock screen'.
- 2) Swipe upwards with one finger on the touchscreen to access Makin' 3D.
- 3) If no project has been previously loaded, you will be prompted to do so. See Chapter 4.1: *Open or create a project.*

3.3.2. Elements of the work screen

Makin' 3D offers a variety of screens to choose from. Below is a description of one that includes most of the available visual features.



1. Top bar with status indicators for connectivity. It also contains features for resetting the pan and zoom level as well as changing between screens.
2. Indication of the slope in the main direction of the tool point. The arrow indicates the vertical distance to the selected height reference. The arrow will change color depending on the distance to the target. Tap the indicator to change the height tolerances.
3. Indication of the slope in the cross direction of the tool point. The arrow indicates the horizontal distance to the selected side reference. The arrow will change color depending on the distance to the target. Tap the indicator to change the side distance tolerances.
4. Info bar for Easting, Northing and Height coordinates.
5. Tap any element in the loaded 3D model to bring up the References dialog.
6. Tap the bucket (also in the static views) to change or calibrate the machine's bucket.
7. *Station*: Indicate where on the centerline you are located. To the right of the Station, you can see the slope along the road





CL: Distance to centerline. To the right of the CL, you can see the slope across the road.

Height: Name of current Height Reference













Side: Name of the current Side Reference.
8. Change the height offset according to the current reference - e.g. the specified plane or the loaded model file.

Quick keys are shortcuts to features found in the menu.
- 9.





3.3.3. Touch gestures

Gesture	Action
	Use one finger to rotate a 3D View.
	Use two fingers to pan a Top View or 3D View.
	Spread or pinch two fingers to respectively zoom in or out of a Top View or 3D View.
	Tap to select.
	Sometimes it is possible to long-press for further options.

3.3.4. Symbols in the top bar

Symbol	Function
	Indicating a connection to the internet. The symbol appears white when a connection is established and gray if there is no connection.
	Indicates the number of visible satellites. hRMS (Horizontal Root Mean Square) and vRMS (Vertical Root Mean Square) indicate the current GNSS accuracy. Tapping the icon will bring you to the GNSS status menu.
	Indication of synchronization of data between server and machine.
	An indication that you have remote support from Makin. This will usually be in connection with a remote support case where you will be notified.
	Bring your machine back to the center of your screen after zooming and panning.
	Placed in the upper right corner. Tap for a change of screen, depending on the work you are doing and what you want to have in focus.
	Toggles between 2D (top view) and 3D view. This button is always placed on the work screen that it toggles.
	Indicating project offset. The symbol appears when a project offset is applied to the active project.
	The tablet is connected to the cloud.
	Synchronize to the cloud.
	The tablet is not connected to the cloud.
	The tablet is disconnected from the cloud because of a secret project.
	This symbol is a sensor status indicator. See the pop-up notification for more information.

3.3.5. Quick keys on work screen

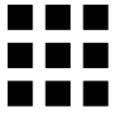
Illustration	Menu ID	Function
	References	<p>Tap to access the <i>References</i> menu. Another way to access this menu is to select an element in the 3D model.</p> <p>NB! Long hold to access the <i>Project menu</i>.</p>
	Log point	<p>Tap to quickly log a point, which will be stored alongside general as-built data.</p> <p>NB! The name of the current object is shown on the icon's label.</p> <p>NB! Long hold to access <i>Objects</i>. You need to select an object before logging a point.</p>
	Log line	<p>Start logging a line by adding line log points.</p> <p>NB! You can select a line and edit it. Select it as a Point of Interest, name it, and add a comment to it. You can also edit the line point's offset. You need to select an object before logging a line.</p>
	Disable log line	Stops the line logging.
	Bucket menu	Tap to access the <i>Bucket menu</i> .
	Main menu	Menu from where you can access all features of the system.

Main menu

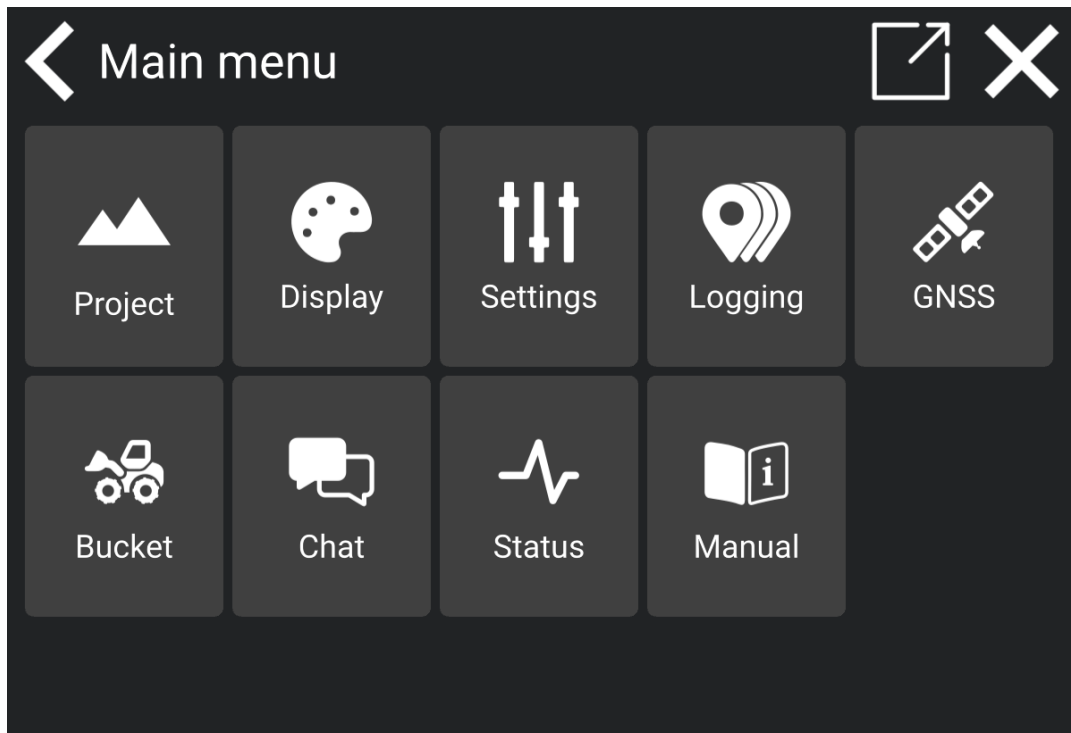

4. Project

Working according to any kind of design is considered a project, whether it is a simple relative plane or referencing lines and surfaces in more complex 3D models.

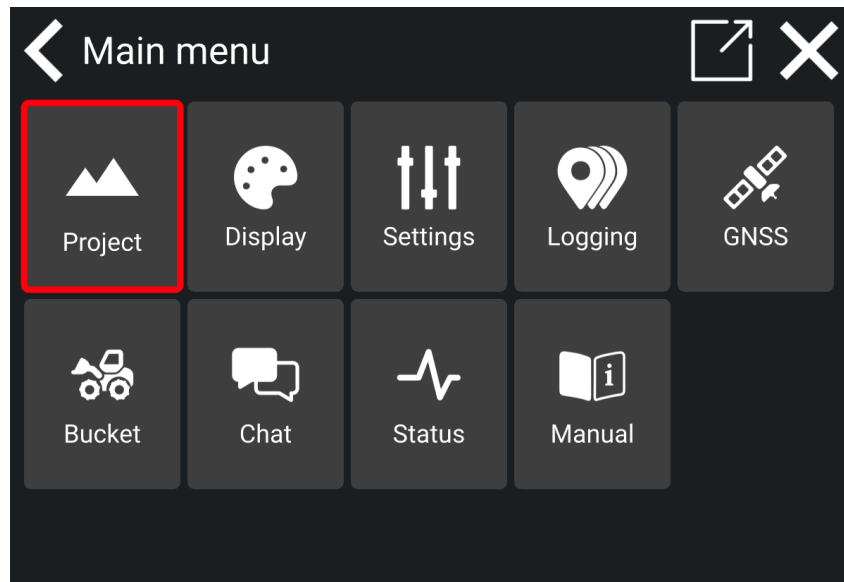

4.1. Open or create a project

To open an existing project:

- 1) In '**Project**' tap '**Open project**' to see all the projects stored. This dialog is automatically opened if no project is loaded.

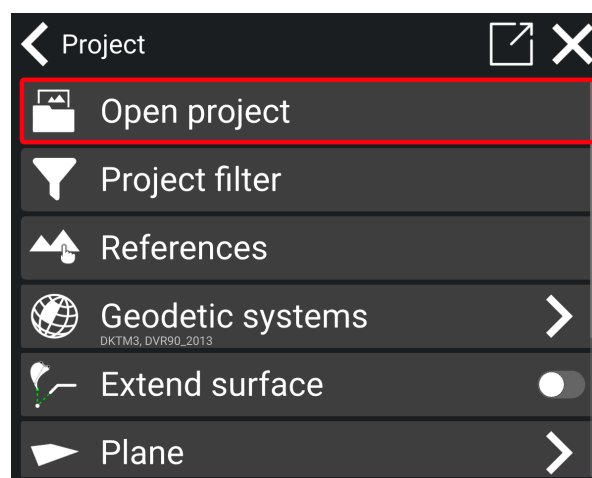

2) Tap on the project you want to open, and the download starts.

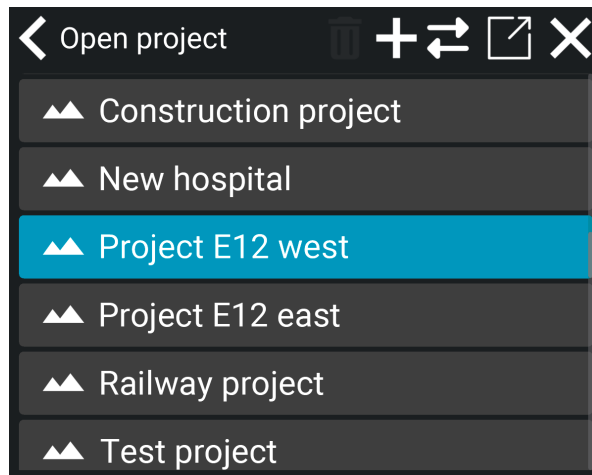

3) If you want to create your own local project, tap the '+' icon.

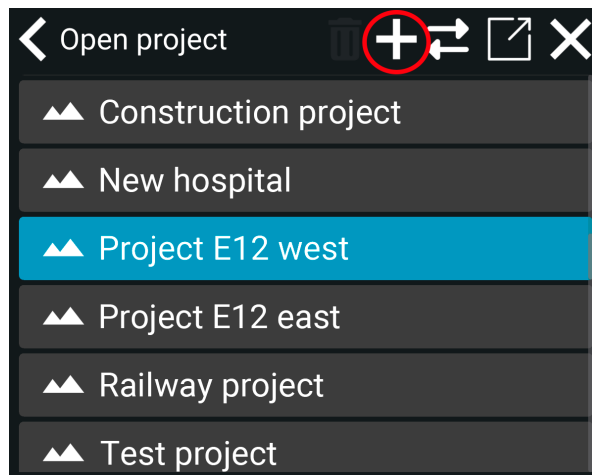

4) Tap on the **local project** icon.

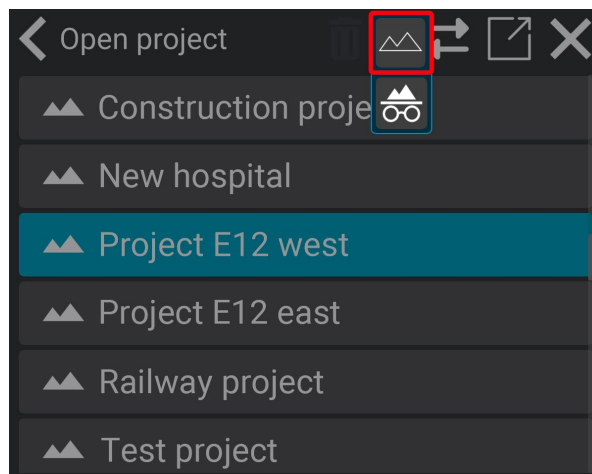

4.1.1. Create a secret project

You can create a secret project that will only be available on your tablet and will not synchronize to the Makin' Cloud. Secret projects are useful for construction projects needing confidentiality due to security, critical infrastructure, or competitive advantages.

- 1) Go to *project > Open project*
- 2) Tap on the '+'-symbol
- 3) Tap on the '**secret project**' icon

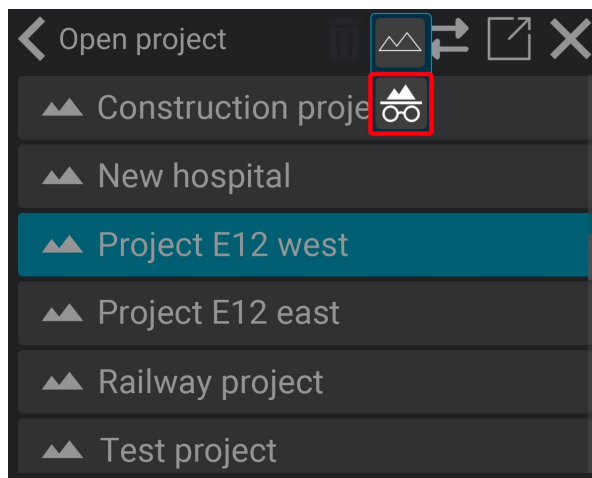

- 4) Name the secret project

The icon in front of the project name indicates that it is a secret project:

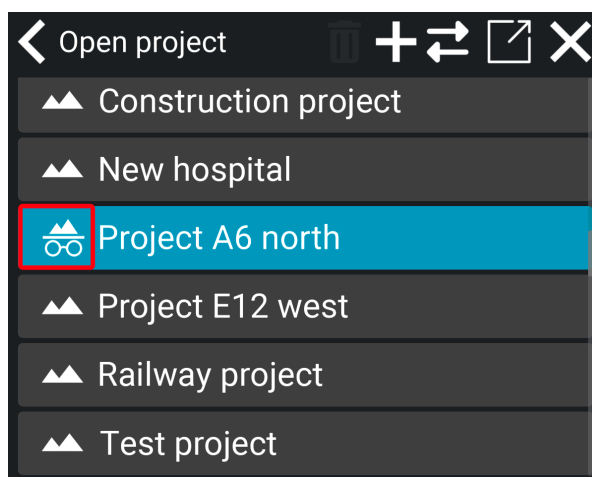

4.1.1.1. Remote control for secret projects

If you need support while working on a secret project, you must grant support access to your tablet during remote control. The secret project will be disconnected and will not synchronize to the Makin' Cloud, as indicated by this icon:



The support staff can see that your system is online on the Makin' Cloud, but they will not have access to any details about the secret project. To get support while working on a secret project, you need to give access to the support staff. When the support staff initiates remote control, a notification will pop up on your tablet:

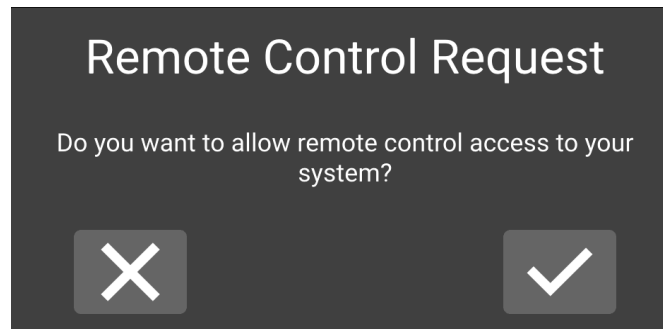

To allow remote control access, tap on the check mark.

4.2. Transfer files

You can transfer files via USB flash drive to secret projects, local projects and cloud projects. You can import files to the project and export as-built data from the project. *Please note:* If you import files to a local project or a cloud project, those files will be available on Makin' Cloud. For more details, see section 4.2.1.1., **Imported files on Makin' Cloud.**

- 1) Tap on the **'transfer files'** icon.

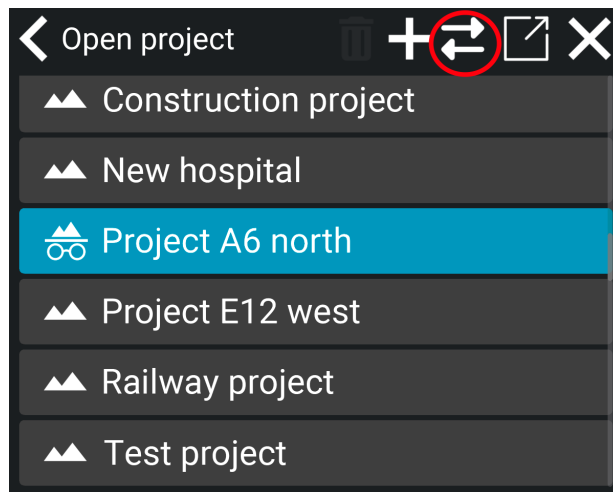

- 2) Choose between **import to project** or **export as-built** data from the project. Learn more about importing and exporting in the sections below.

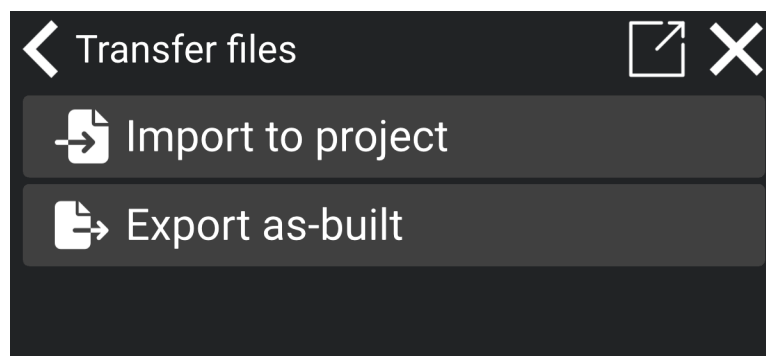

4.2.1. Import to project

You can import files to the project via a USB flash drive. You cannot import single files but only folders from the USB flash drive. *Please note:* If you import a file with the exact same name as an existing file in the project, the new file will overwrite the existing one.

How to import files to the project:

- 1) Important: Insert the USB flash drive into the tablet first.
- 2) Tap on 'Import to project'.

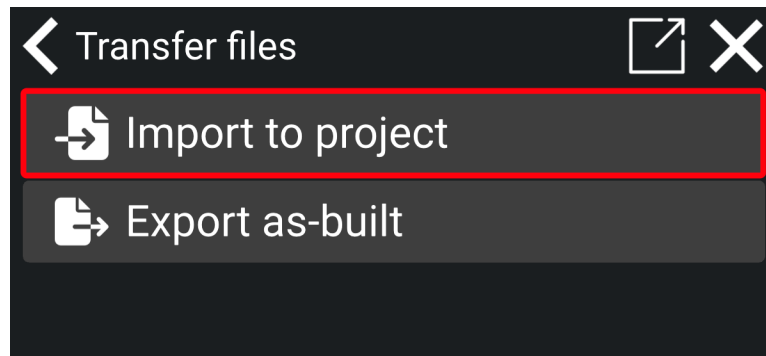

- 3) You will now be directed to Android's dialog.
- 4) The first time you insert the USB flash drive you need to make sure that the USB flash drive is selected. Tap on the 'three stripes' icon in the top left corner.

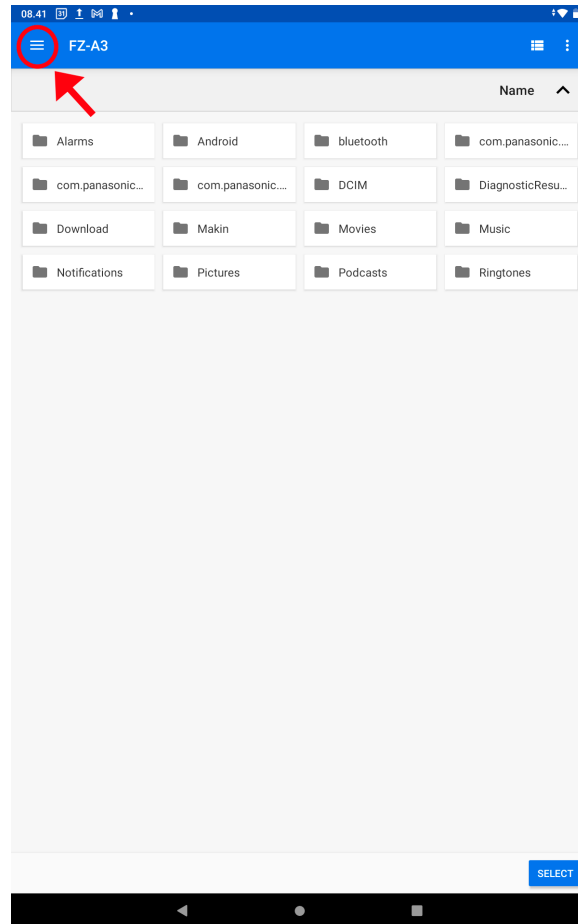

5) Tap on the name of the USB flash drive to open it.

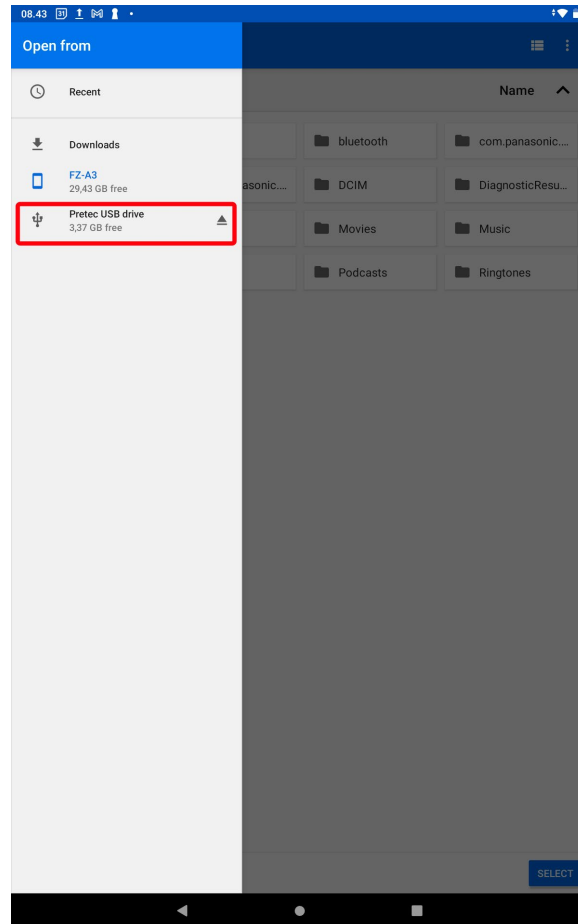

6) Tap on the folder you want to import files from.

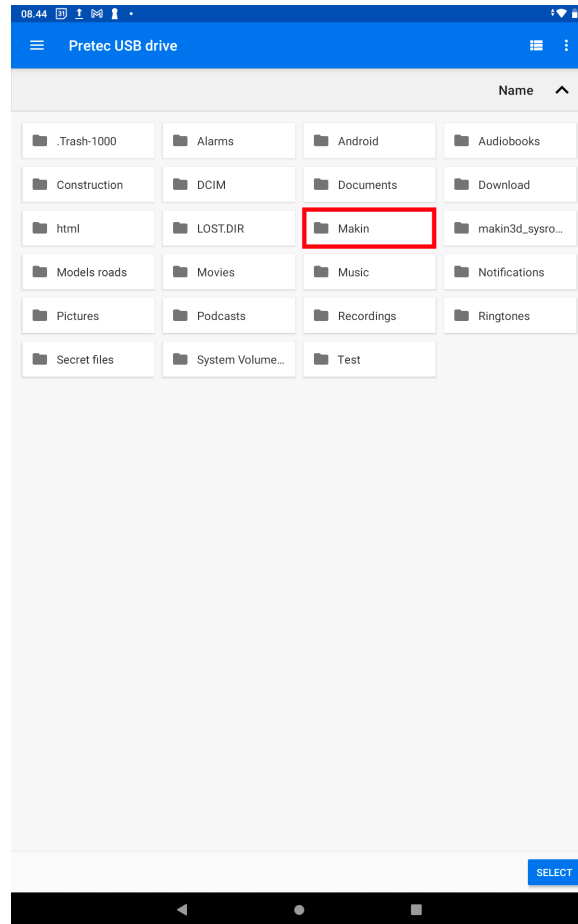

7) Tap on **'select'**. *Please note:* All the files in the folder will be imported. You cannot import single files.

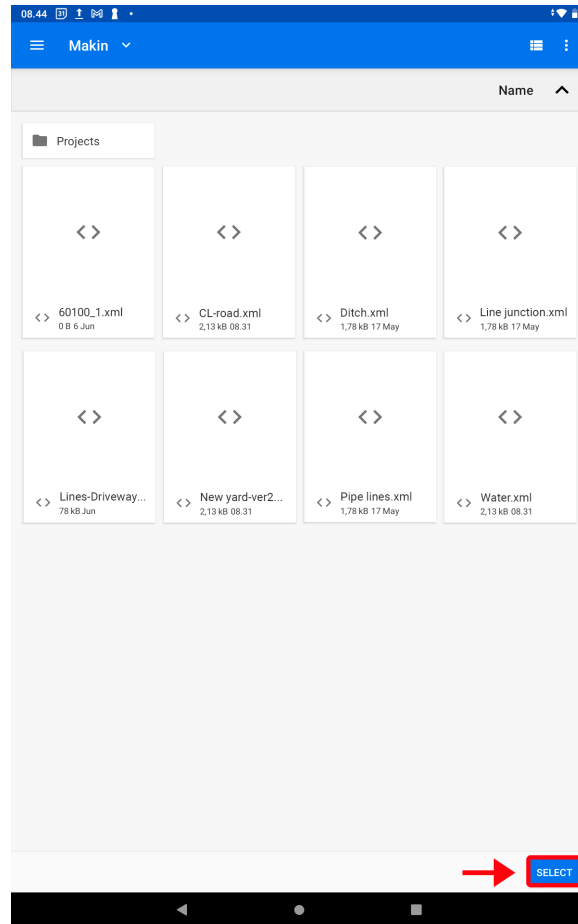

8) Import of files is completed. You can view the files under *Project > References*. The imported files will be marked with a *.

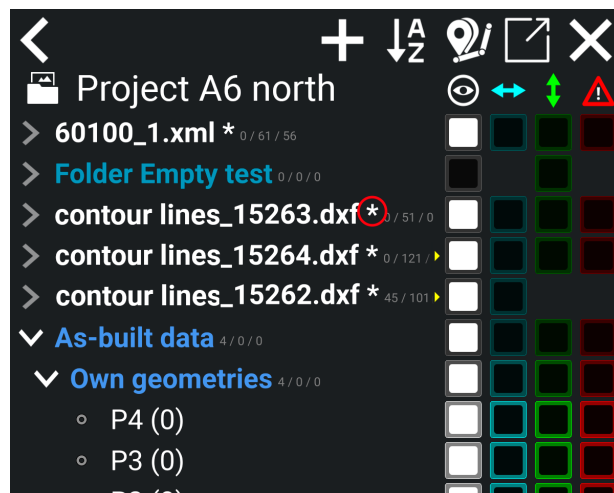

4.2.1.1. Imported files on Makin' Cloud

When you import files to a local or cloud project, they will be available on Makin' Cloud. However, these files will be stored in your system's project folder, and not as part of a global project within your organization.

How to find imported files on Makin' Cloud:

- 1) Go to *Makin' Cloud* > *Choose organization* > *Systems*

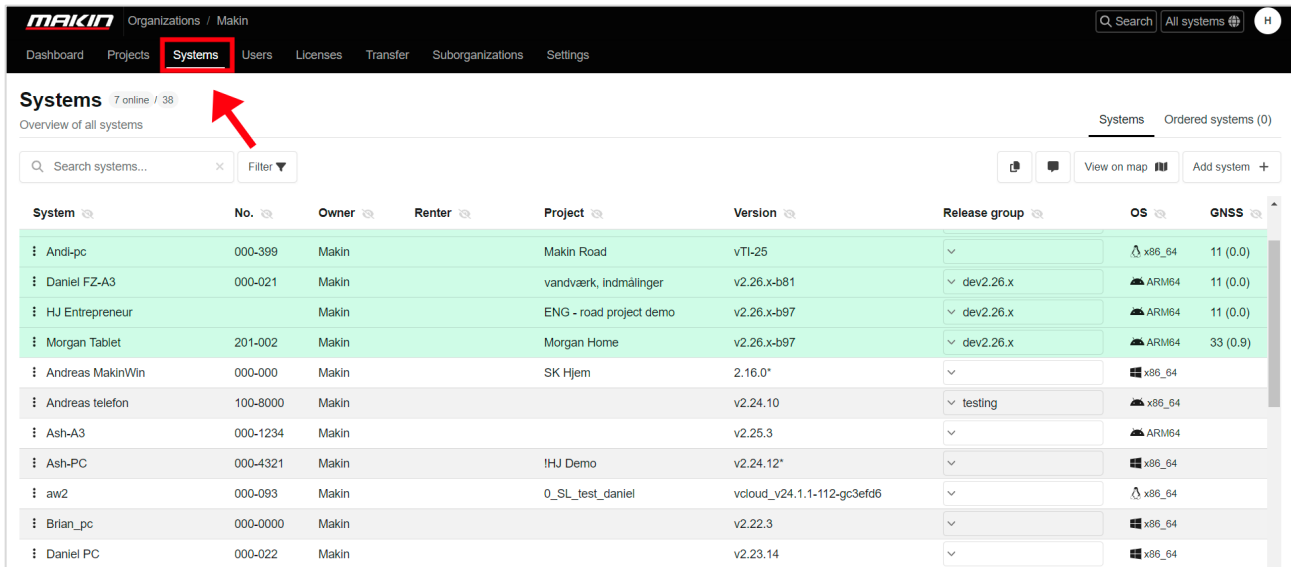

Systems 7 online / 38

Overview of all systems

Search systems... Filter

System	No.	Owner	Renter	Project	Version	Release group	OS	GNSS
Andi-lpc	000-399	Makin		Makin Road	vTI-25		x86_64	11 (0.0)
Daniel FZ-A3	000-021	Makin		vandværk, Indmålinger	v2.26.x-b81	dev2.26.x	ARM64	11 (0.0)
HJ Entrepreneur		Makin		ENG - road project demo	v2.26.x-b97	dev2.26.x	ARM64	11 (0.0)
Morgan Tablet	201-002	Makin		Morgan Home	v2.26.x-b97	dev2.26.x	ARM64	33 (0.9)
Andreas MakinWin	000-000	Makin		SK Hjem	2.16.0*		x86_64	
Andreas telefon	100-8000	Makin			v2.24.10	testing	x86_64	
Ash-A3	000-1234	Makin			v2.25.3		ARM64	
Ash-PC	000-4321	Makin		!HJ Demo	v2.24.12*		x86_64	
aw2	000-093	Makin		0_SL_test_daniel	vcloud_v24.1.1-112-gc3ef06		x86_64	
Brian_pc	000-0000	Makin			v2.22.3		x86_64	
Daniel PC	000-022	Makin			v2.23.14		x86_64	

- 2) Select the system that imported the files.

- 3) Open the **project folder** under that system.

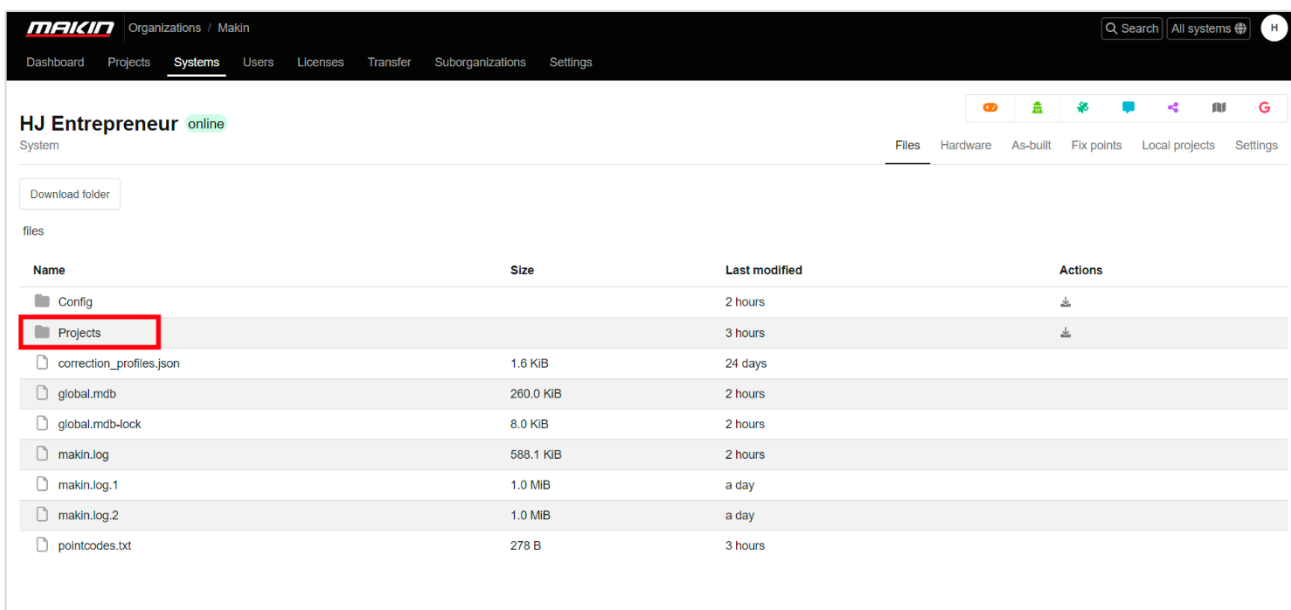

HJ Entrepreneur online

System

Files Hardware As-built Fix points Local projects Settings

Download folder

files

Name	Size	Last modified	Actions
Config		2 hours	
Projects		3 hours	
correction_profiles.json	1.6 KiB	24 days	
global.mdb	260.0 KiB	2 hours	
global.mdb-lock	8.0 KiB	2 hours	
makin.log	588.1 KiB	2 hours	
makin.log.1	1.0 MiB	a day	
makin.log.2	1.0 MiB	a day	
pointcodes.txt	278 B	3 hours	

4) Select the **project** where the files were imported.

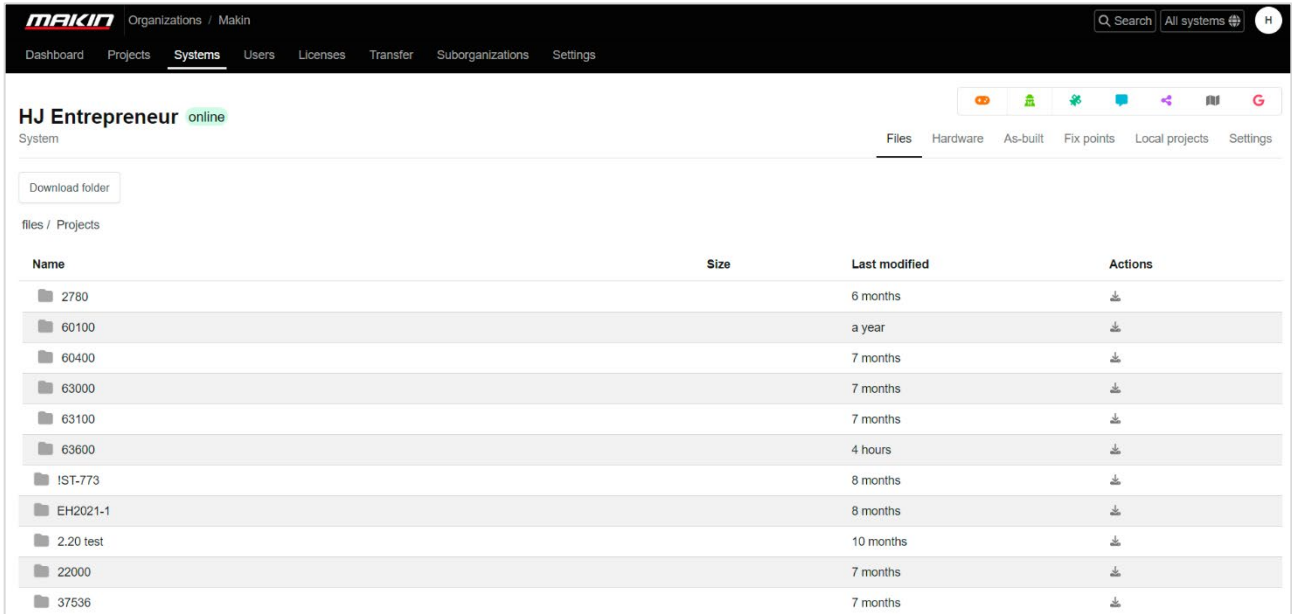

5) The imported files will be available in this folder.

4.2.2. Export as-built

The USB export function allows you to export locally logged *as-built* data directly to a USB stick. This makes it possible to transfer project data without requiring access to the cloud.

Note: Only the as-built data logged by the current user can be exported.

When performing a USB export, the following files are generated:

- LandXML file: Contains points and lines from the as-built logging.
- ZIP file (*attachments*): Photo documentation for all images linked to the logged points.

Steps to Export As-Built Data via USB:

1. Insert the USB flash drive into the tablet. Please note that it is very **important** that this is done as the first step.
2. Open the menu *Open project*.
3. Tap the icon displaying the two arrows (Transfer symbol)
4. Tap on '**Export as-built**'.

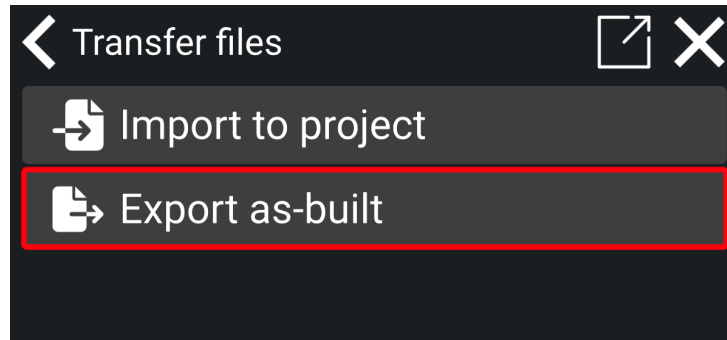

5. You will now be directed to Android's dialog.
6. Make sure that the USB flash drive is selected. If not, tap on the 'three stripes' icon in the top left corner and select the USB flash drive.

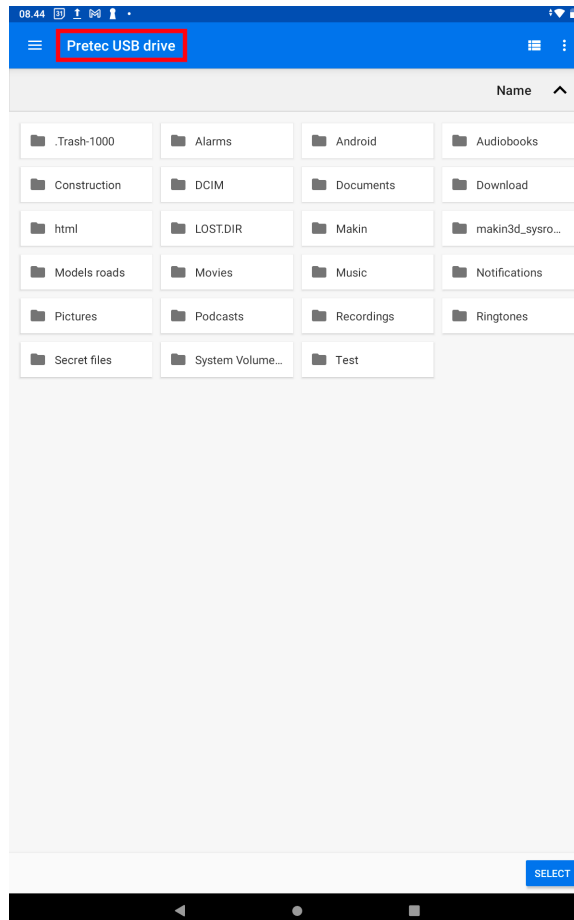

7. Tap on the folder where you want to save the as-built data.
8. Tap on '**Select**'. This will export the project's as-built data to the chosen folder. A pop-up notification will indicate that the export is in progress.

 - Please note that in most cases, the process is completed so quickly that this notification may not appear.

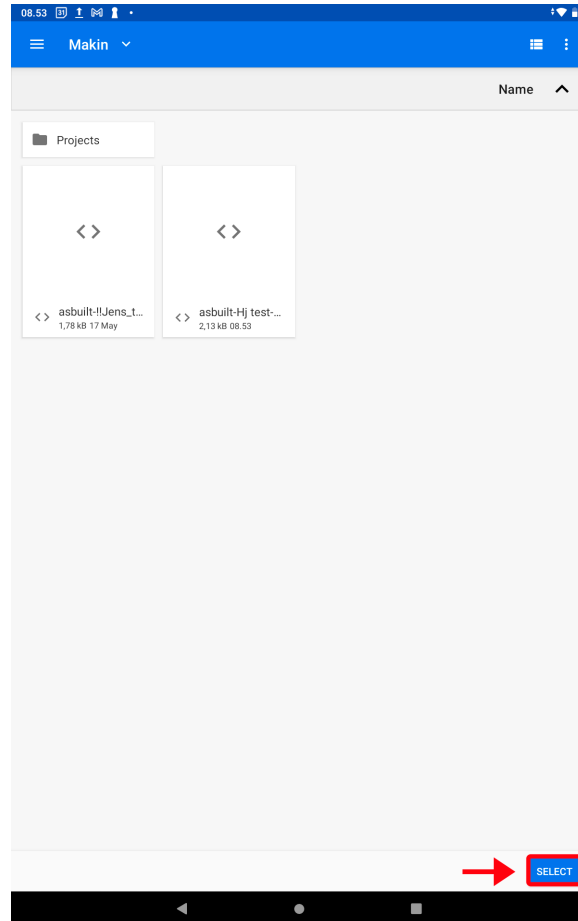

9. The project's as-built data is now saved in the selected folder on the USB flash drive. When the export is complete, a confirmation pop-up will be displayed on the screen.

4.3. Supported file types

When creating a project, the following file types are supported:

- LandXML Roadrunner format (XML)
- Drawing eXchange Format (DXF)
- Norwegian coordinate and observation format (KOF)

New projects are stored in LandXML format.

4.3.1. Project filter

Note: When Makin' 3D reaches 170 MB data in size, a warning will pop up, informing you that the project is large. This can reduce performance. The file size depends on the complexity and the details in the model.

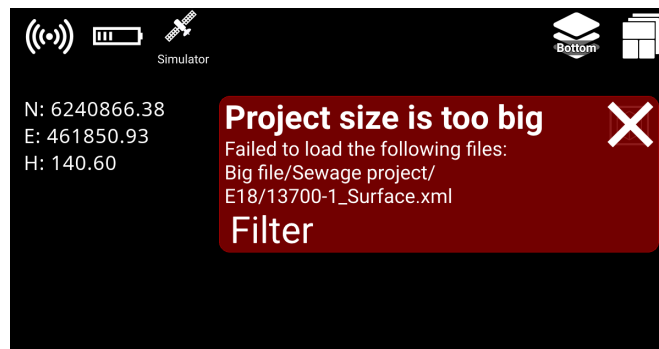

If the project reaches 170 MB data in size, part of the model will be shown on your tablet screen near the application, while the rest remains hidden. As you move the application around, the visible part of the model will adjust to stay aligned with where your application is.

You can choose to load a part of the project file under *Project > Project filter* or click '**Filter**' in the notification (see picture above).

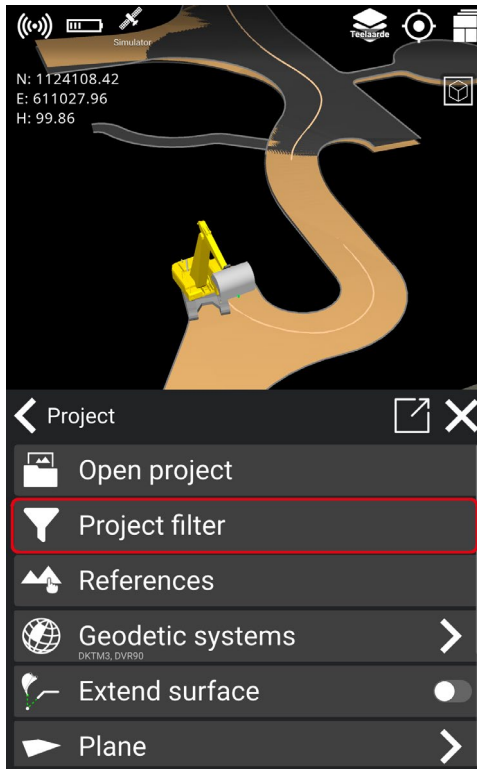

- 1) Select the folder you want to activate and load by clicking on the button. When the folder is activated, the button will turn blue.

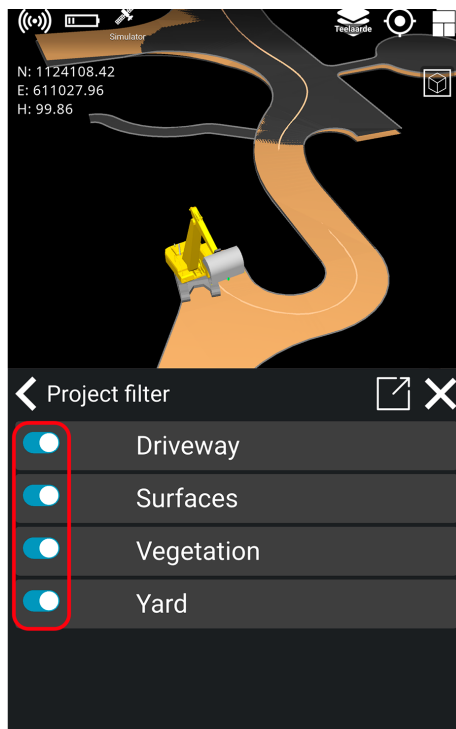

- 2) Deselect the folders you do not want to load by clicking on the button in front of the folder's name. When deselecting the folder, the button will turn off.

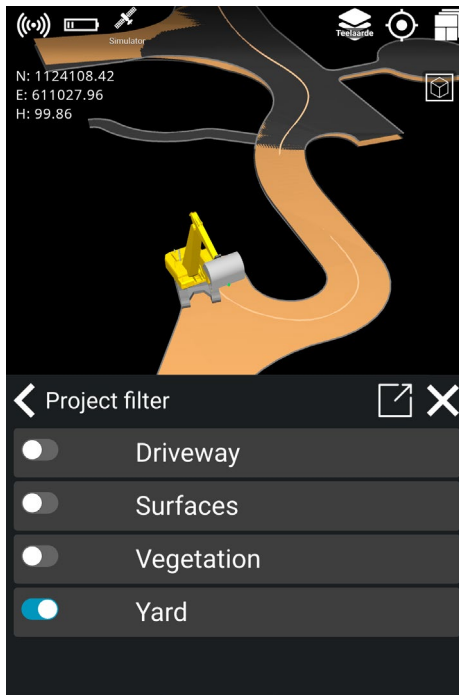

The activated folders will be loaded and displayed under 'References' in a petrol blue color, along with the files from the folders.

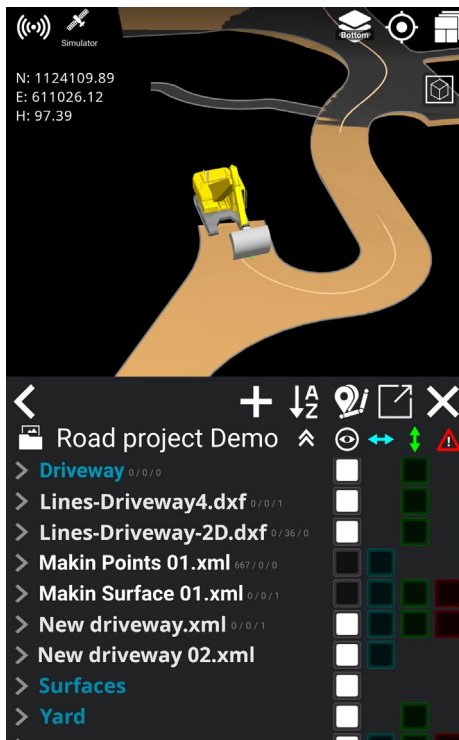

You can create folders on Makin' Cloud and then drag your project files into these folders: *Makin' Cloud > Project > Choose your project > New folder.*

4.4. References

In the 'References' dialog, you can choose which part of the 3D model should be active/inactive and what should be selected as height references, side references, and alert references.

Height references can be points, lines, and surfaces.

Side- and alert references can be points and lines.



1. Tap one of the symbols to select all elements in the project

4. Green is used for elements that may reference the height. Press to select as reference. Long press will deselect all

2. White means an element is visible and activated

3. Blue indicates an element used as a side reference. Press to select as reference. Long press will deselect all other side references selected

other height references selected

5. Red is an alert reference, which gives a warning when the tool is too close to the element. Not applicable for surfaces.

6. Highlight elements with yellow color in the 3D model

As an alternative to going via the menu, you can also find this feature in the **Quick Keys menu** or by selecting any element in the 3D model.

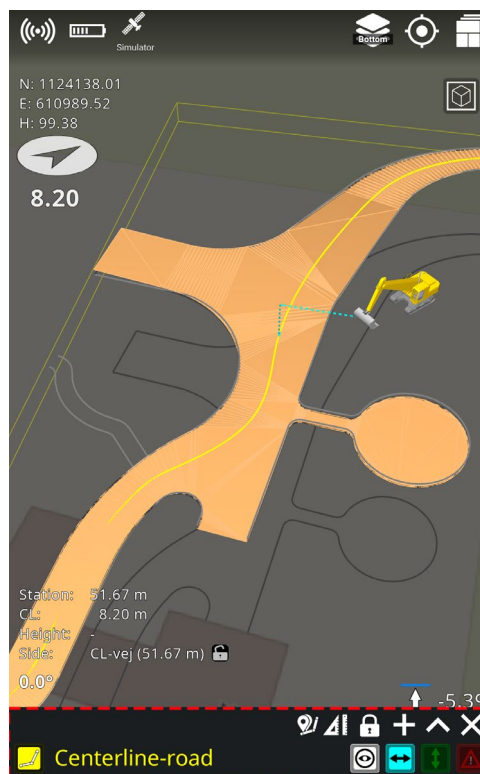

4.4.1. Folders

In the reference examples below, we see all the data that has been entered on a road parcel.

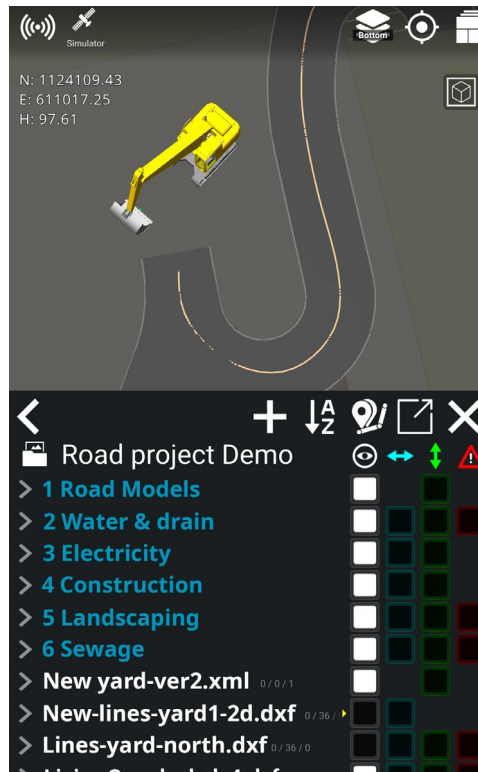

In this example, we have six folders:

- Road Models
- Water & drain
- Electricity
- Construction
- Landscaping
- Sewage

If you enable options (i.e., set visible, side reference, height reference, alert reference) for a folder, you enable the option for all models in the entire folder. For example, if you have many road models, you may want to open the folder with the small gray arrow to the left of the folder and only activate the road models that you need.

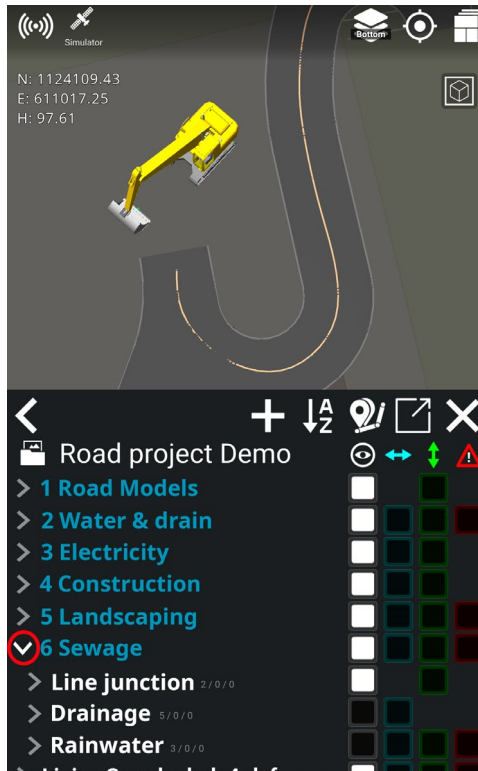

Folders are shown in blue text - model files are white. File and folder names are scrollable, indicated with a tiny yellow arrow to the right of their names. A star following a project name indicates the project is local.

In the above example, we have opened the folder for road models, which contains several individual files. You can turn on all elements of a folder or turn on some details by expanding individual folders. Within the folders, you can select specific data to make visible and choose what to actively work against.

To get an indication of the different model files, side and/or height must be activated. As with viewing, you do this by tapping the respective blue and/or green boxes. By enabling visibility, side, and height in combinations, you can customize what information you want on the screen.

4.4.2. Visible reference

All geometries are visible by default and can be hidden by deselecting the white square next to them, beneath the eye symbol. Calculations are only performed according to visible layers.

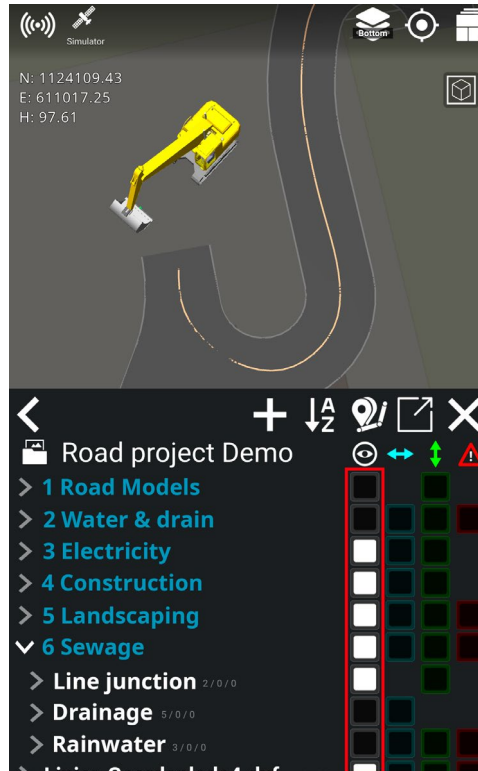

For example, if we want to make all roads visible in a group of models, simply check the white box to the right of its folder. It will make all roads visible on the screen. If we only want to see one road, just activate the white box to the right of the particular road file.

4.4.3. Side reference

Side references are geometries used for side calculations. When models are activated, they have a blue color next to them, beneath the symbol with the horizontal arrow in the 'Reference' dialog. The closest geometry, activated for side reference, will automatically be used. Lines and points can be selected as side references - not surfaces. The calculated side distance is the horizontal distance to the geometry.

4.4.4. Height reference

Height references are geometries used for height calculations. They are indicated with a light green color when activated in the 'References' dialog, beneath the vertical arrow symbol. The lowest geometry, with height reference enabled, will automatically be used. Height references are typically surfaces, but lines and points can also be selected for height calculations.

4.4.5. Alert reference

Alert references are geometries used for alert calculation. The closest geometry activated as an alert reference with a red square beneath the warning symbol will automatically be used. Lines and points can be selected as alert references - not surfaces. Unlike the calculation of side reference, the calculated alert distance is the closest Euclidean distance (shortest path) to the geometry.

4.4.6. As-built data

As-built data is data used for documentation of the performed task. As-built data can be used in different ways: to document that the project is built the same way as it was originally designed or to document if extra work has been performed, e.g., how much soil is being removed from an area.

The as-built data is collected when the machine works, and the data is logged by the operator. This data can be used later in the process to assure the quality of the project and/or to calculate the volume of material that is added or removed from an area. As-built points will be saved in the overview if it is necessary to navigate to the points at a later stage of the project.

As-built data can be used as references in a similar way as other references. The green points are your own points, and the purple points are points from other applications. The lines and points are continuously saved and synchronized to the Makin' Cloud, where they can be downloaded as .CSV, .KOF or .XML formats.

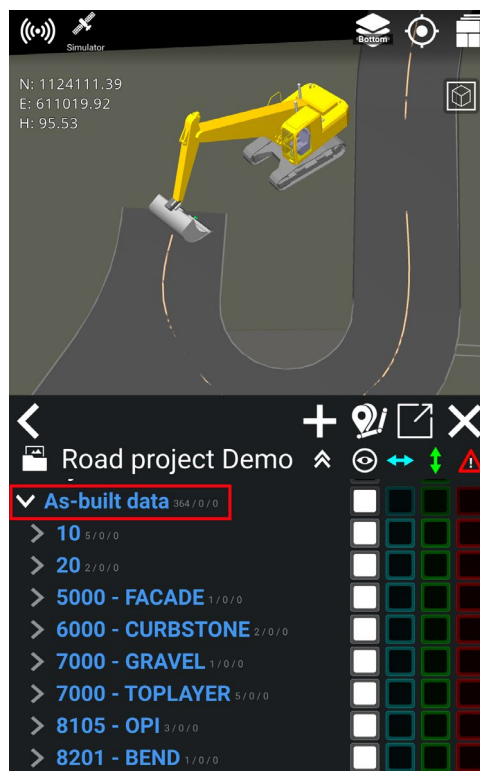

4.4.7. Lock Reference (line, point, or surface)

Makin can work with multiple active references at the same time. This allows the user to activate and work with the references when moving the tool point over them. The active reference will automatically switch to the one closest to the tool point. While doing this, and with a lot of references often close together, it can be difficult to avoid the references from switching if you want to navigate to a specific height or side reference or to a reference further away than other selected references. In this case, the user can lock a reference, isolating the navigation to this specific reference without deactivating all other active references.

You can select and lock a line, point, or surface that will be used as a reference.

If you are moving the tool point around on the project, the height and side reference will keep being locked to the selected reference, thus keeping this as the reference.

Locking a reference can be done in the reference menu or directly on the work screen:

- 1) Select an object by pressing the object name or directly on the visualized object on the run screen.
- 2) Press the **lock icon** to lock the selected reference.



- 3) Select 'Side', 'Height' or both:

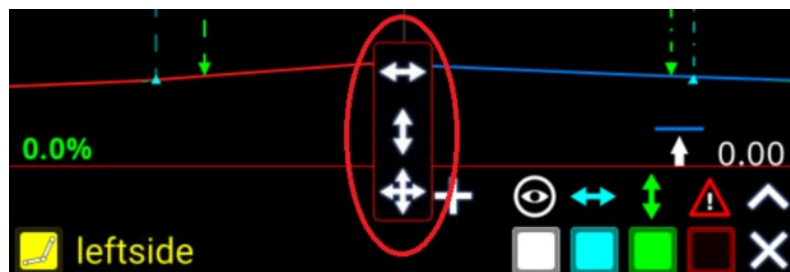

You can see that both 'Side' and 'Height' have a lock on them.



- 4) If you want to unlock it again, just tap once on the lock, and it will disappear.
- 5) If you want to lock the reference directly under your tool point, this can be done by pressing the lock icon next to the reference name in the work screen. This will toggle the lock icon between open and closed for either height or side reference.



4.4.8. Dynamic 2D files

2D files, also known as background files or display models, are defined as files with no height information available. The height of all points in the file is set to 0.00 meters. These files are often used as background to visualize existing infrastructure or drain pipes where height was not logged originally. When working on projects with the 2D files, they are not placed at a height of 0.00 meters. They are moved closer to the project, right below the active 3D references' lowest point. These files are handled dynamically, so whenever a 3D reference is activated or deactivated, the 2D files adjust accordingly.

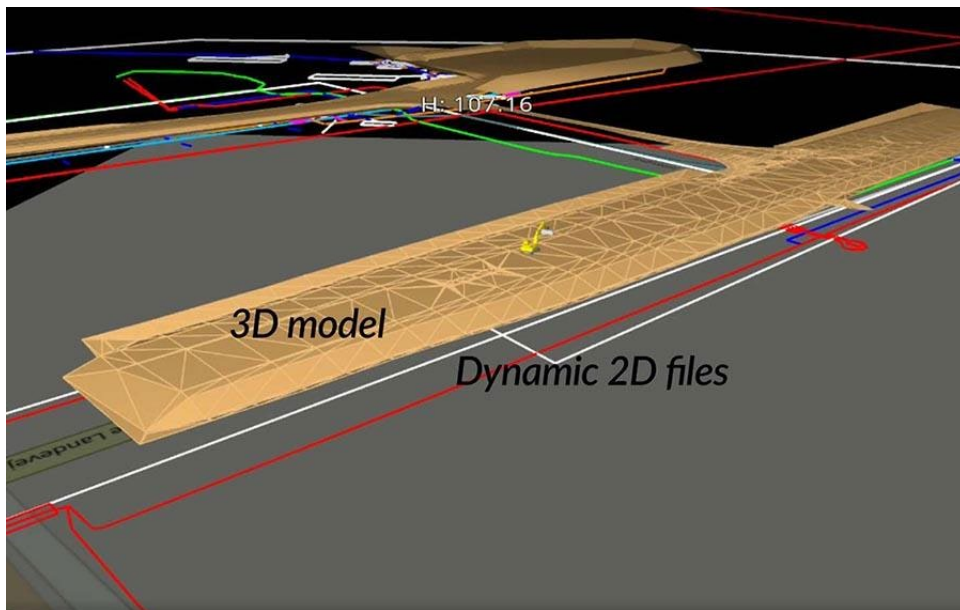

4.4.9. Copy Point

You can now copy and edit a point by selecting one from the design model. However, it should be noted that you are not able to modify the points in the design model itself.

By using the edit feature, you can change the point's properties, such as its height. The edited point will be saved under your own points list (*user model*).

Additionally, you can utilize the Copy Point feature to duplicate any points from your personal point list.

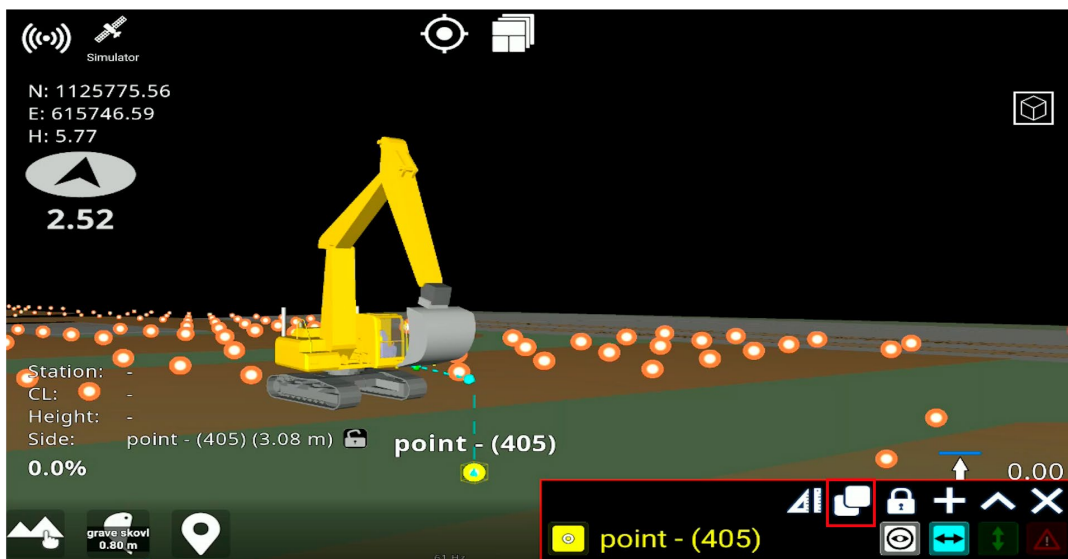

4.4.10. Stakeout

Stakeout shows the information for the selected line, point, or point on a line. To stake out an element, press the element in the graphics or press the element name in the reference dialog, and press the stakeout icon at the top of the reference dialog. A popup will appear with all the stakeout information for the selected element. The stakeout menu can be freely moved around on the tablet.

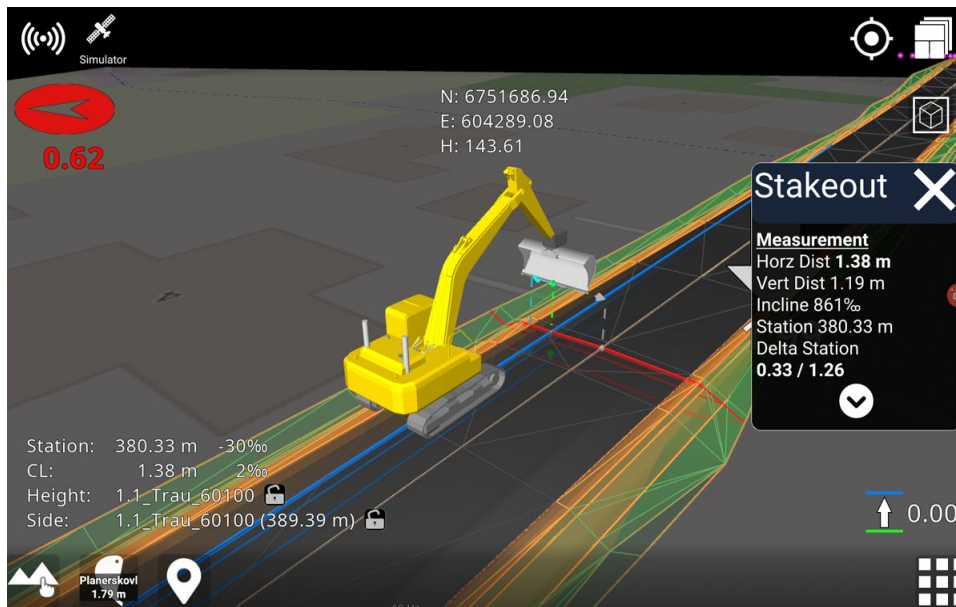
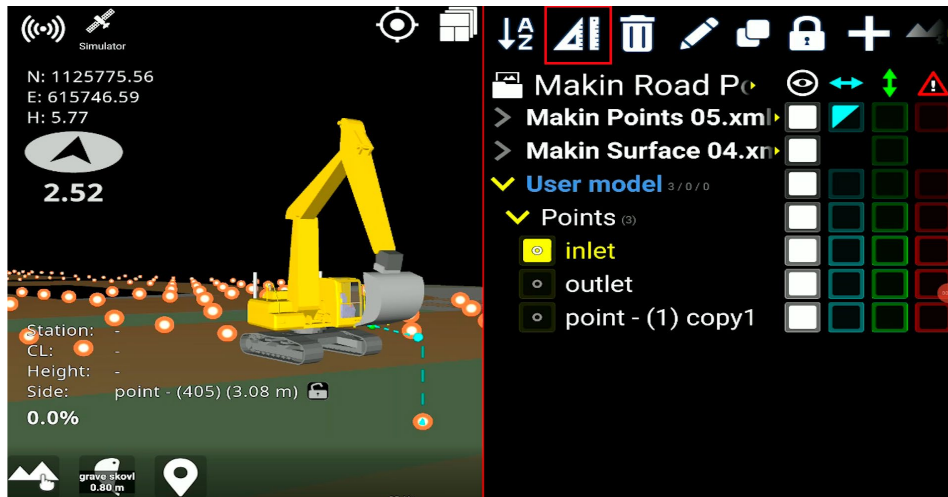

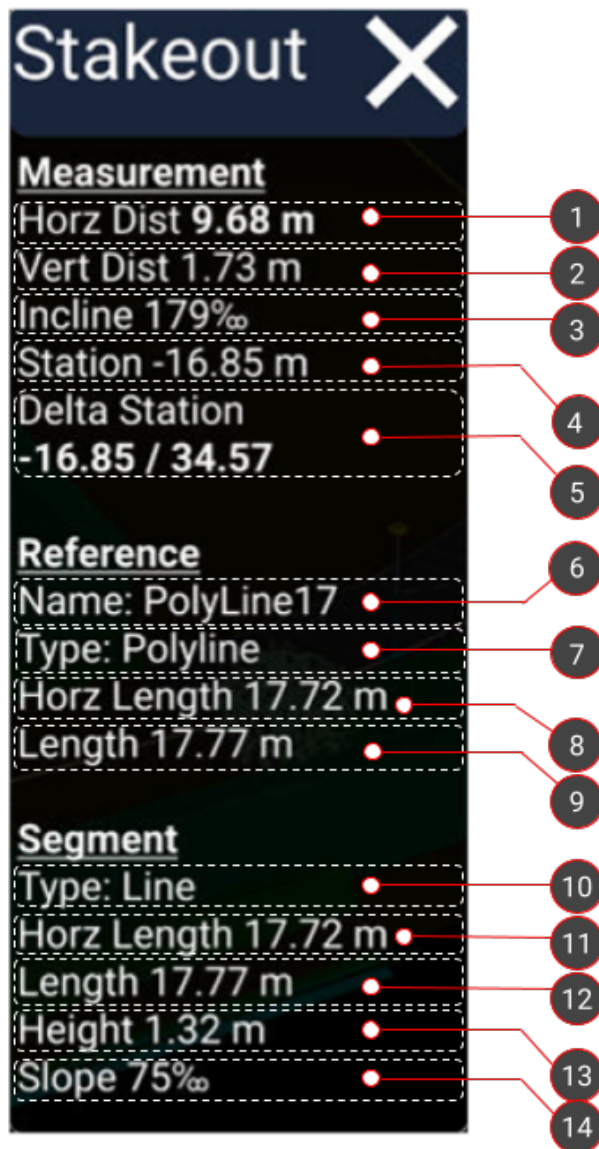

Measurement: Shows measurements between the tool point and the selected reference for the stakeout.

Reference: Shows information about the entire selected reference for stakeout.

Segment: Shows information about the active line segment (gray line). Only shown for lines that contain segments.

- | | |
|---|--|
| 1. Horizontal distance between tool point and selected reference. Measured perpendicular to the line. | 8. Horizontal length of stakeout line. |
| 2. Vertical distance between tool point and selected reference. | 9. Length of stakeout line. |

3. Inclination between selected reference and tool point.
4. Stationing of the selected line.
5. Horizontal distances from present stationing to the end points of the active line segment (colored gray). The line will be extrapolated, if the tool point is in front or behind end points. In this case, the value will be negative to the closest end point.
6. Name of selected stakeout line.
7. Type of selected reference (arc, circle, line, polyline, road line)
10. Segment type can be line, arc, or clothoid (spiral, transition curve).
11. Horizontal length of line segment.
12. Length of line segment.
13. Height difference of the line segment.
14. Slope of the line segment.

4.4.10.1. Stakeout to a point

When you want to stake out to a point, you can press the point or click on the name of the point in the reference dialog, and then press the stakeout icon .

A bullseye and a popup with the stakeout information will appear on the screen. The blue line in the bullseye indicates the long slope direction, and the red line indicates the cross slope direction.

The popup with the stakeout information will show information about measurement and reference.

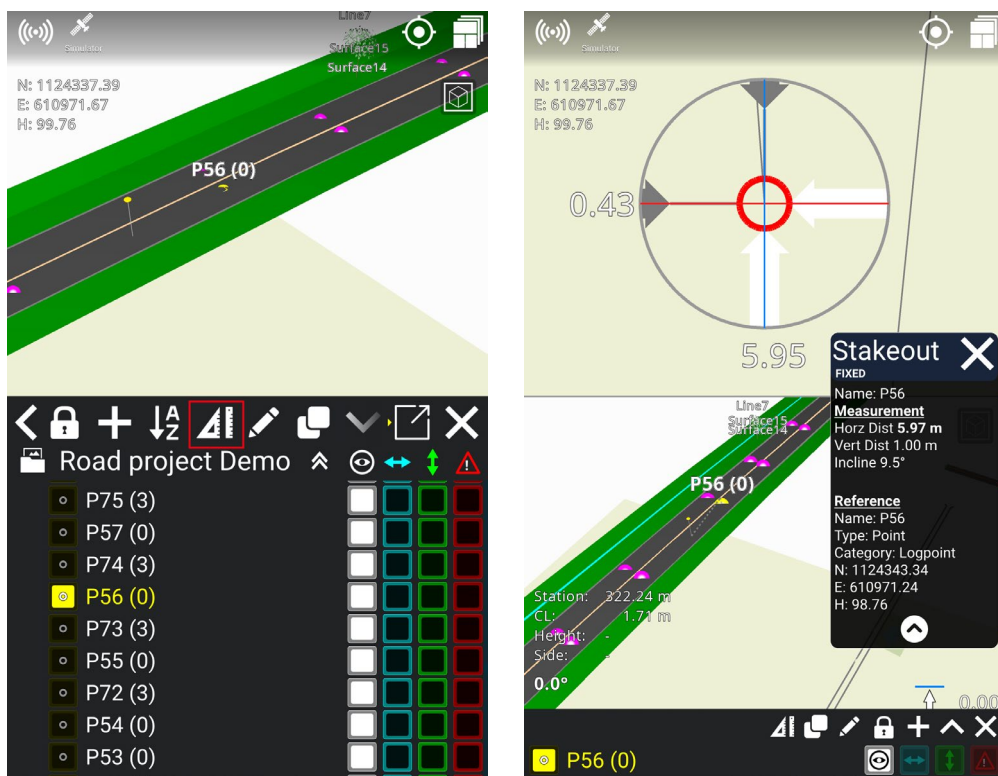

4.4.10.2. Stakeout to a line



When you want to stake out to a line, you can press the line on the screen or click on the name of the line in the reference dialog, and then press the stakeout icon .

A dotted line from the application to the selected line will show on the screen, along with a popup with stakeout information. The stakeout information will show information about measurement, reference, and segment.

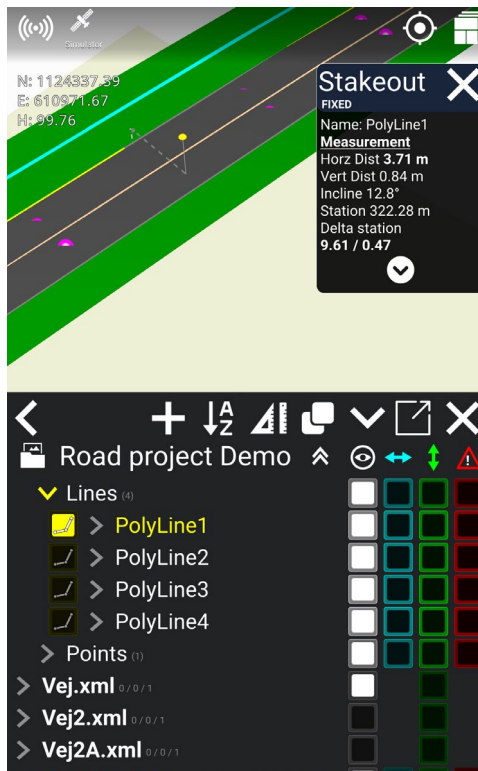
If you move beyond the line, the dotted line will show the extrapolation of the selected line. Please note that if you stake out to a side reference, the line does not extrapolate.



4.4.10.3. Stakeout to a line point

If you want to stake out to a point on a line, you must press the arrow between the line symbol  and the name of the line in the reference dialog. Then the name of the line point will appear underneath the arrow. Select the line point you want to stakeout to, and then press the stakeout icon .



A bullseye and a popup with stakeout information will appear on the screen. Like stakeout to a point, the blue line in the bullseye indicates the long slope direction, and the red line indicates the cross slope direction.

The popup with stakeout information contains information about measurements and references.

4.4.10.4. Stakeout to side reference

You can stake out to side references, which allows you to see multiple elements' information by jumping between them when you use the stakeout feature.

How to use:

- 1) Activate the elements you want to use as a side reference by pressing the boxes underneath the blue horizontal arrow in the reference dialog. When you activate a box with a blue edge it will change to a fully blue box.
- 2) Press the stakeout icon .
- 3) The application will now stake out to the nearest element, and when you move around, the application will switch to stake out to a new nearest element. A popup with stakeout information will also appear on the screen.

The popup with stakeout information will show information about the name of the element, so you know which element the application stakes out to. The popup also contains information about measurements and references.

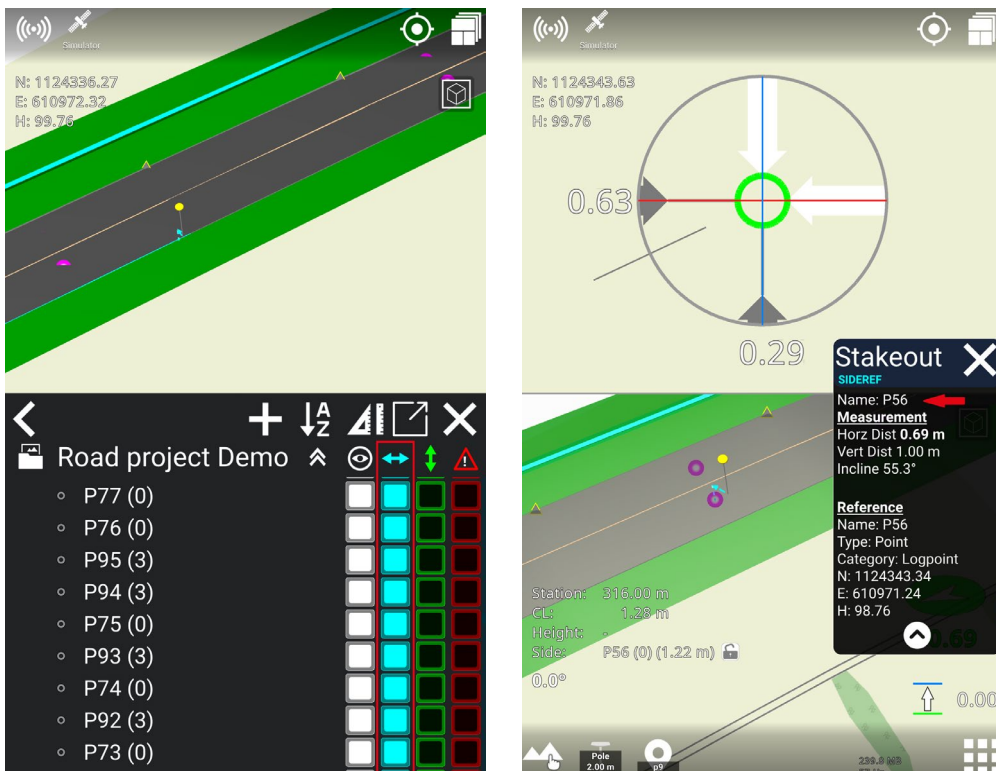

4.4.11. Create point from coordinate

- 1) Press on **References**:

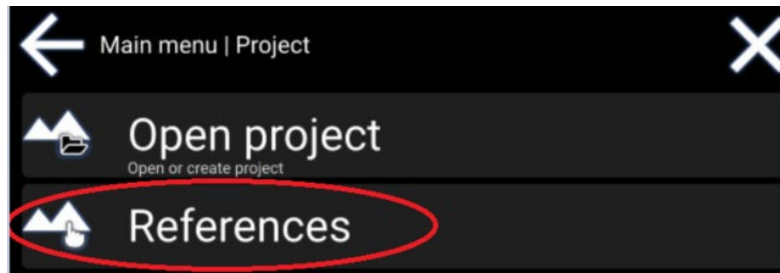

- 2) Press the '+'

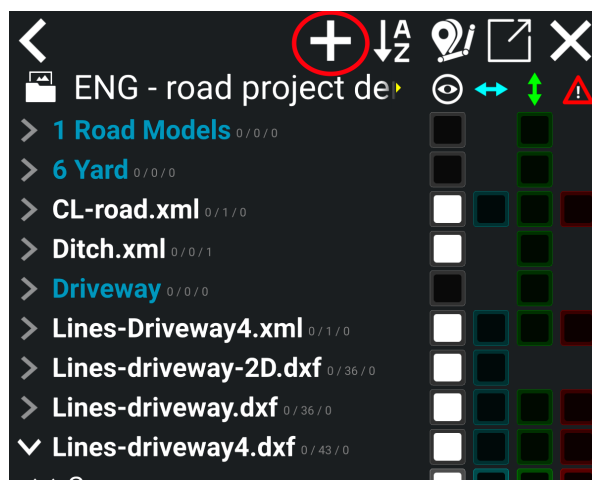

- 3) Press the **point** icon:

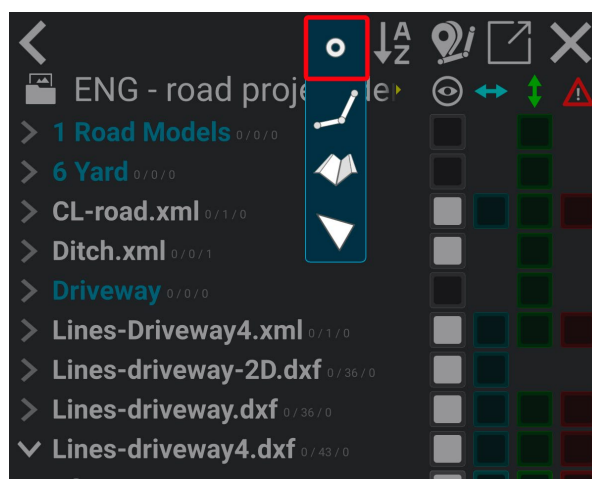

The point will have the coordinates of the tool's selected measurement point.

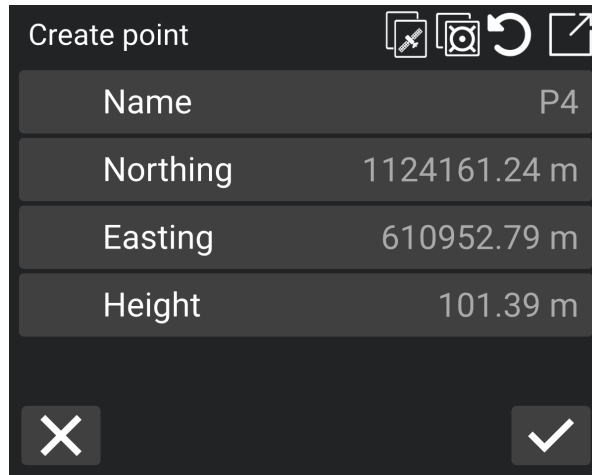

- 4) Set a name for the point.
- 5) The point's coordinates can be adjusted manually.
- 6) It is also possible to adjust the tool's position and fetch the new position of the tool (see *the tool icon in the picture above*).
- 7) Tap the check mark to confirm the new point.

Points you have created yourself can be found at the bottom of the *References* under *User model > Points*.

4.4.12. Create line from points

- 1) From **'References'** tap **'+'** and then **'Line'**.

You can create lines between existing points - either from a design model or from points you have created yourself.

The line will be created in the order in which points are selected, and you will see how the line appears in the on-screen overview.

- 2) You will be prompted to **'Select the points for the line'**.
- 3) Select the points individually by either picking points in the 3D visualization or highlighting the yellow icon next to them in the list.
- 4) Finish by pressing **'OK'**.
- 5) Give the new line a name.
- 6) If you have selected three points or more, you can select the **'Close line segment'** option to connect a line between the first and last points.
- 7) Finish the line by pressing **'OK'**.
- 8) Finish the line by pressing **'OK'**.

4.4.13. Create profile along lines

- 1) From 'References' tap '+' and then 'Profile'  .

The line will function as the centerline for the profile, where you can add any number of surfaces on either side of the line.

- 2) You will be prompted to "**Select the lines for the profile**".
- 3) Select the lines for the profile in the 3D visualization or in the list. When done, tap '**OK**'.
- 4) Give the profile a name.
- 5) Press the '+' button on the left and right side of the screen to respectively add new surfaces on the left or right side of the line.
- 6) Adjust each of the surfaces' width, Deltaheight dH, and angle according to the design that you want.
- 7) You can also adjust the height offset of the entire profile.

4.4.13.1. Edit profile

You have the possibility of editing an existing profile. In this way, you can edit the profile's width and slope of the surfaces, as well as add or remove surfaces.

- 1) Under **User model**; longhold on the profile surface name, which you want to edit.
- 2) Click on the **pen tool**, which will appear.

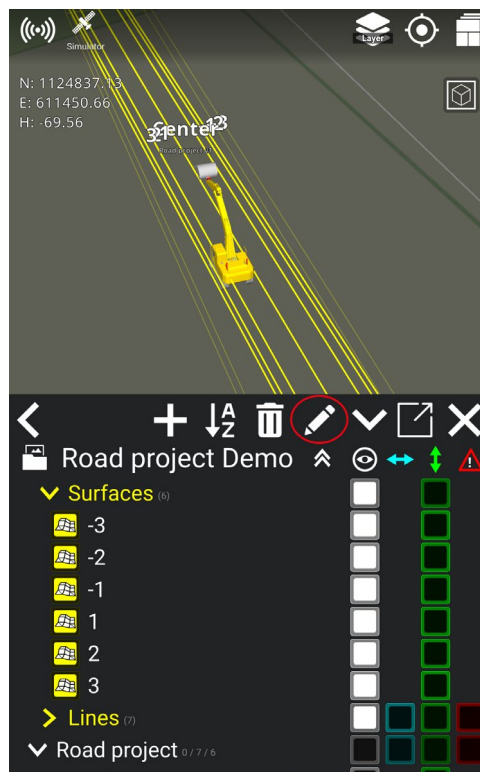

- 3) Adjust the width, the deltaheight dH, and/or the angle of the surfaces by clicking on the numbers you want to change.

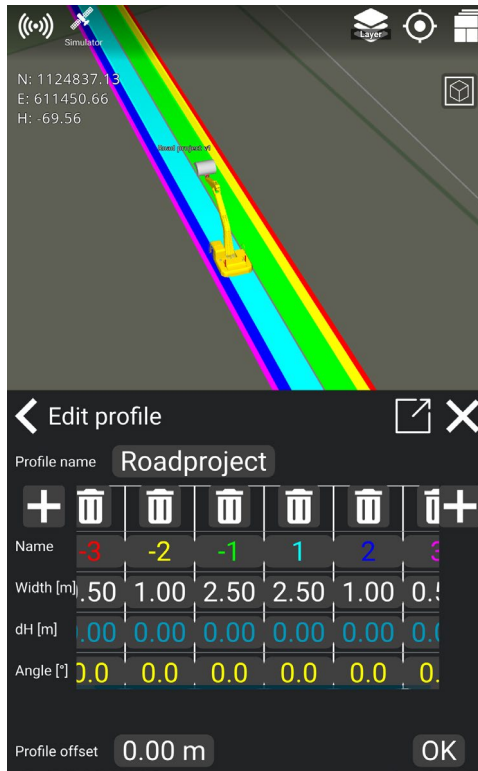

4) The profile will now change according to the new width and slope of the surfaces.

4.4.14. Edit Line

You can edit line points in the user model if you need to change the coordinates/location of an existing line. Be aware that you can only edit your own lines located under the user model, meaning that you cannot edit lines from project- or As-built data.

- 1) Go to *References > User model > Lines*.
- 2) Click on **'Lines'**.
- 3) Choose the line you want to edit by clicking on the line or the arrow in front of the name of the line. For example:

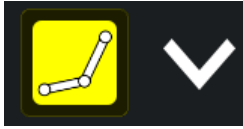

- 4) Click on the point of the line you would like to change, for example:

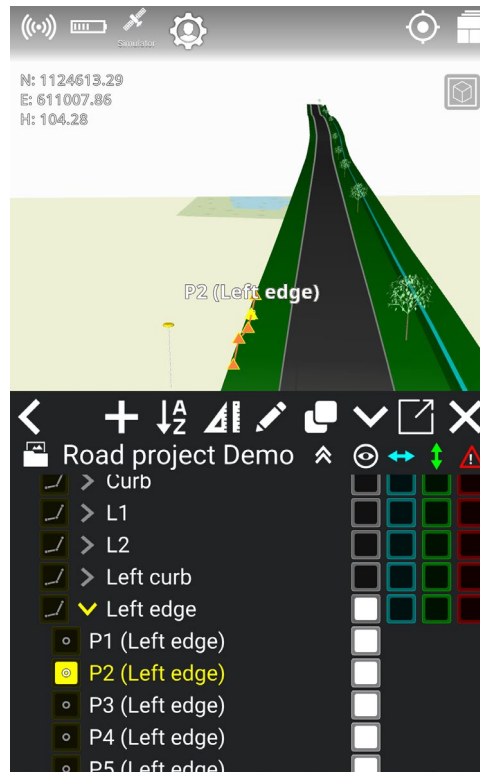

- 5) Click on the **pen tool** to edit the line point.
- 6) Change the desired coordinates of the point's position. The line will now change in relation to the point's new position.

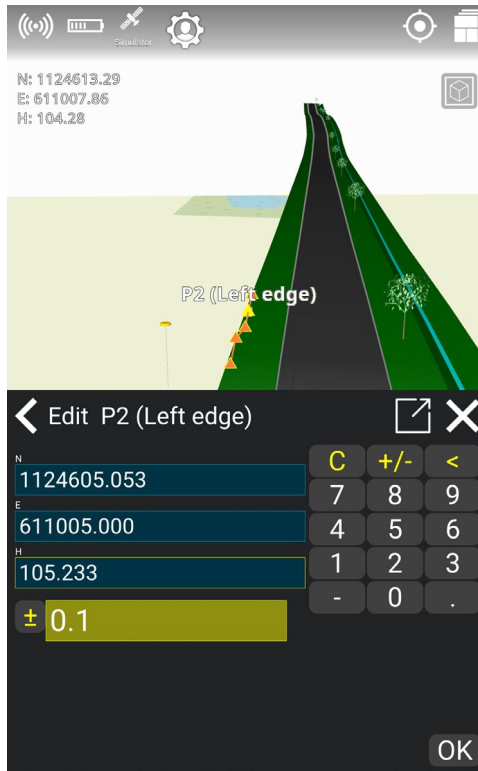

4.4.14.1. Copy a line from design data in order to edit it

Because you cannot edit lines from design data, you can instead copy a line from the design and edit the copied line points in the **User model**. In this way, you can still follow the line and adjust the line points, e.g., if you want to change the height of a line point.

How to copy a line:

- 1) Select the line you want to copy from the design.
- 2) Click on the 'Copy' icon:



- 3) You can rename the copied line. Press **'Ok'** to copy the line.
- 4) The copy is now under **'User model'**, where you can edit the line.

4.5. Infield Design

To open the Infield Design function, go to the *Reference menu*.

1. Click the + icon on the menu bar in top of the *Reference menu*.
2. This will open a drop-down menu. Select the Infield Design icon.

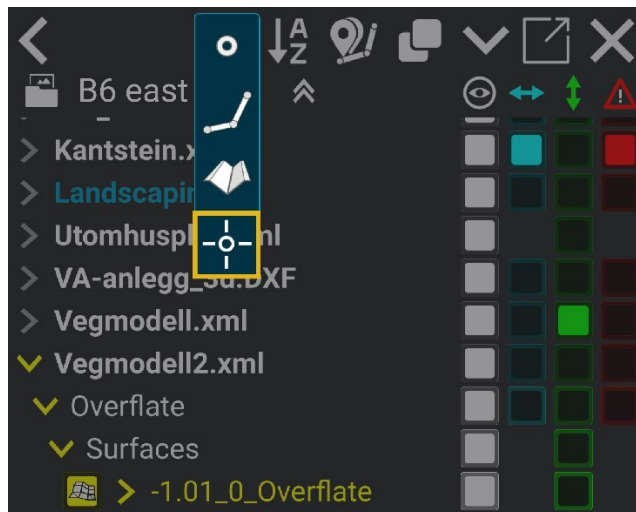

3. Wait for the Infield Design section to open.

4.5.1. Points and lines in Infield Design

The Infield Design is equipped with an *Add point*- and an *Add line*-button.

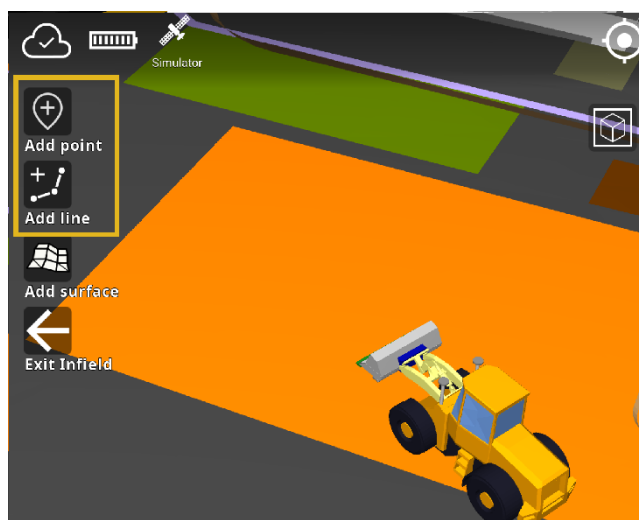

Use these to add the needed data or work from already logged data. The workflow when logging points and creating lines in Infield Design is almost the same as when logging regular as-built data.

1. Click the icon for the data you need to log.
2. Place the tool point in the correct position.
3. Click the *Add point from TP*-button on the screen. This will log a point.

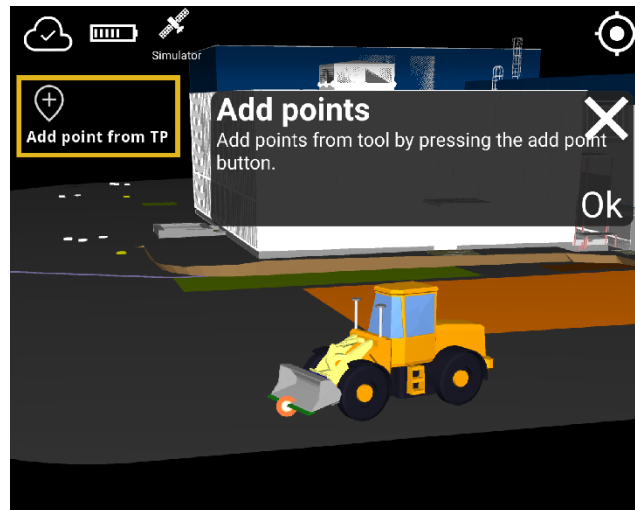

4. Move the tool point to the next position.
5. Repeat until all desired points are placed and click the *OK* button.

Please note: If you close the pop-up window by pressing the X, all data created before pressing *OK* will be deleted, and it is not possible to recover it.

4.5.2. Info box for line

When a line is created, you can access its relevant information. Simply select the line and click the *Info*-button on the left-hand side of the screen. This will open a pop-up window.

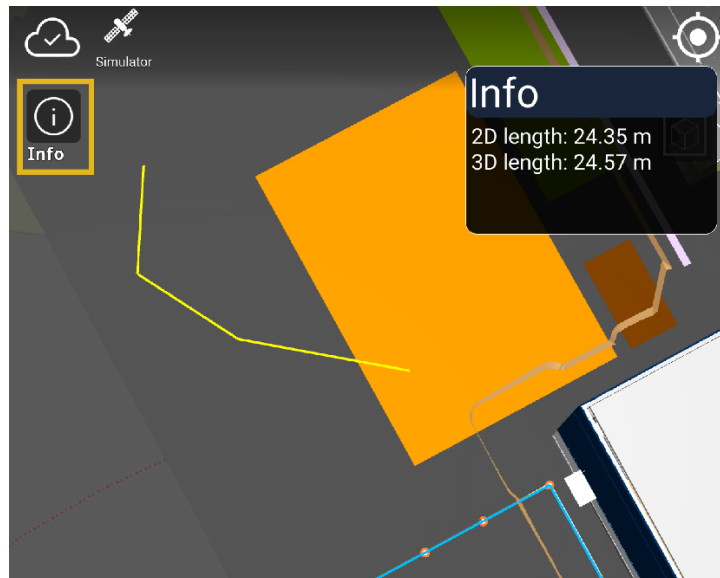

4.5.3. Create a boundary

1. When the points are logged, click the *Add surface*-button.

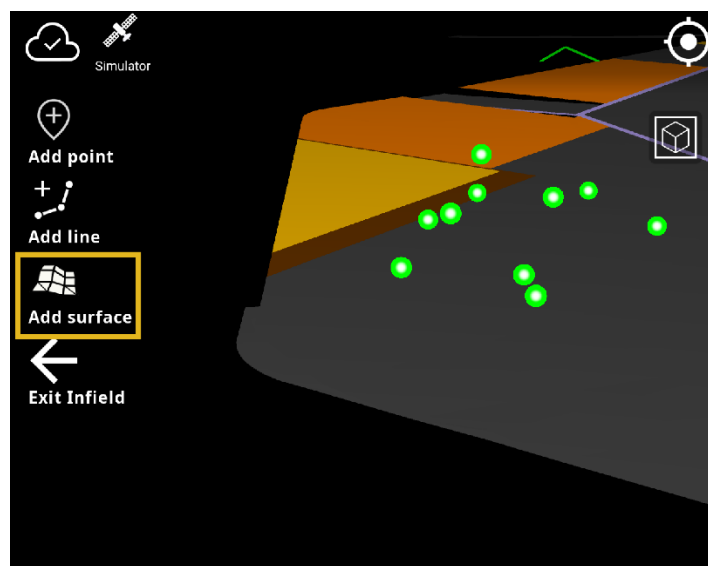

2. Click the *Boundary*-button.

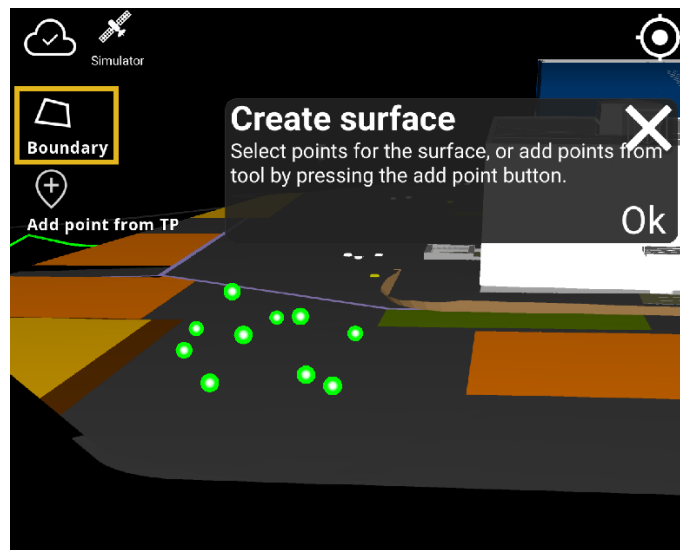

3. Select the points there are a part of the boundary and click *OK*.

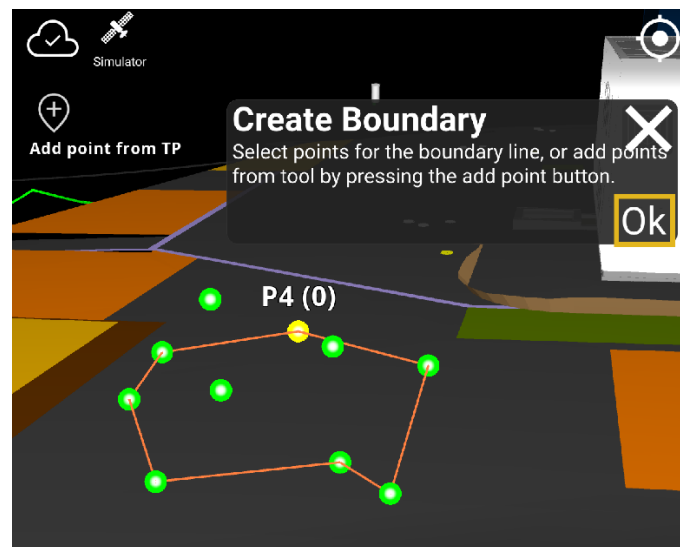

4. A boundary has been created.

4.5.4. Calculate volume

1. Start by creating a surface based on your boundary.
2. Click the *Add surface*-button.
3. Click the *Boundary*-button and select the created boundary. When selected press *OK*.

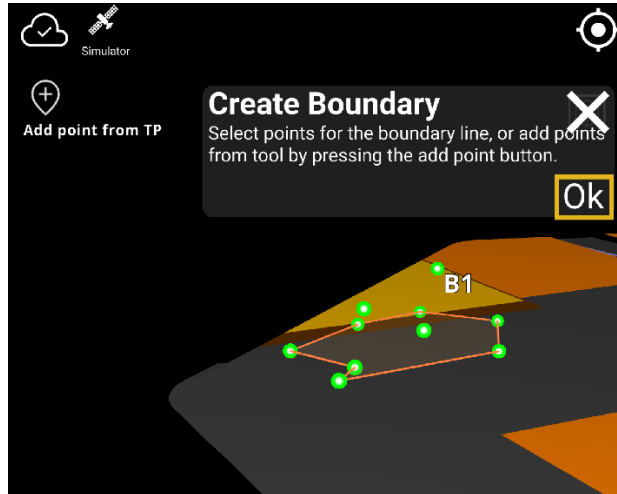

4. Select the top points to create the surface. When the points are selected, click *OK* to create the surface.

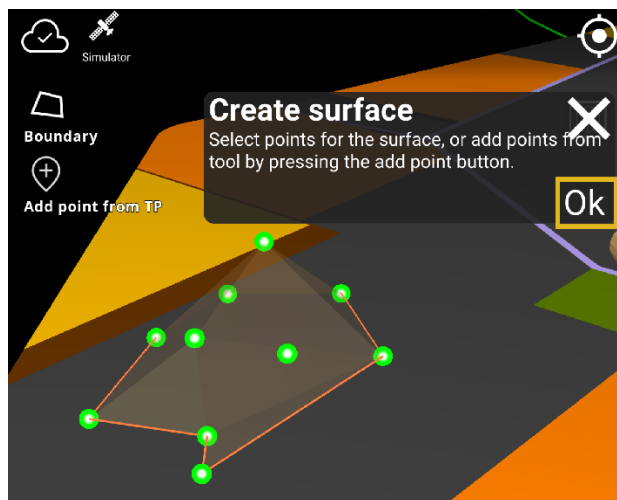

5. Select the surface and click the *Volume to boundary*-button to calculate the volume.

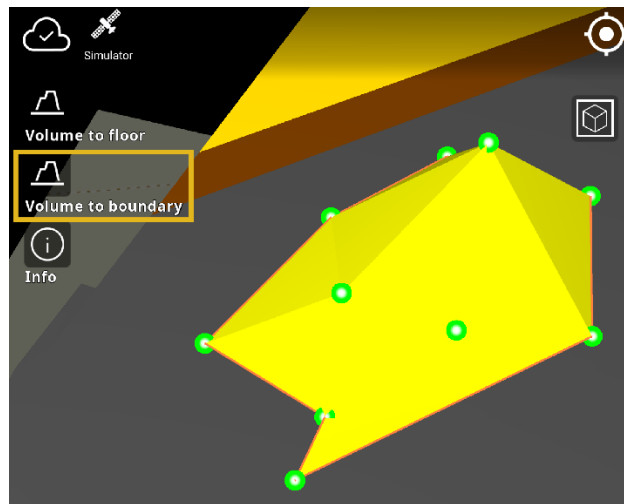

6. This will open a pop-up window showing the volume.

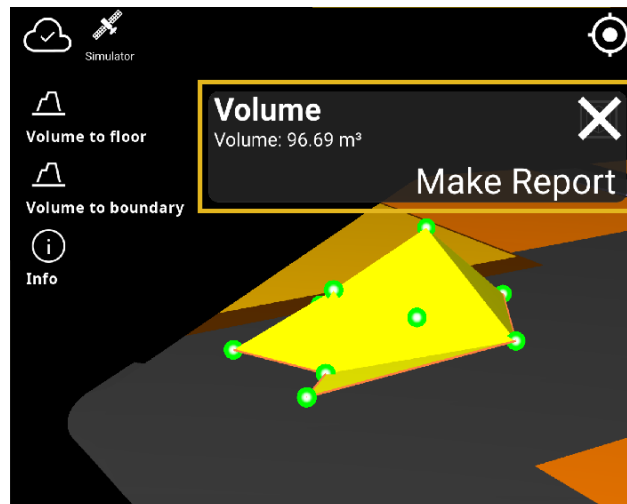

7. If more information is needed, click the *Info*-button to open the info box.

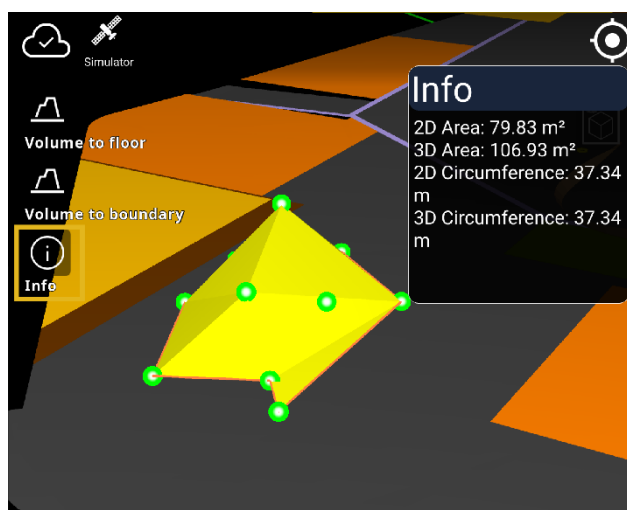

4.5.5. Infield Design report

It is possible to create an Infield Design report with all the relevant measurements. Create the report by clicking the *Make report*-button, this will export the data to Makin' Cloud. Please note that the report can only be generated once the volume has been calculated and Infield Design has collected all the relevant data.

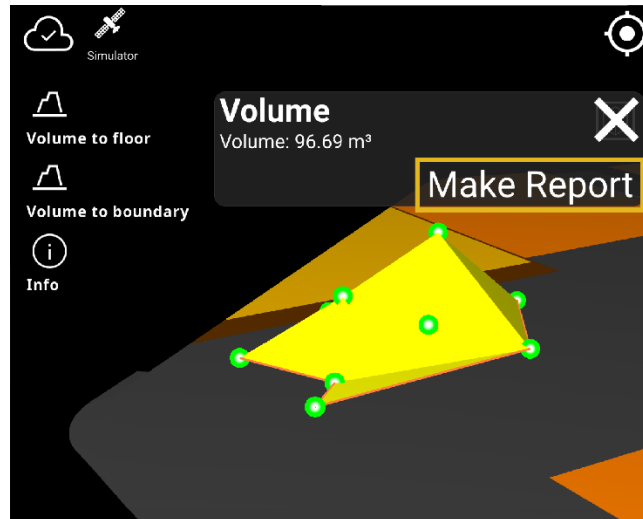

Go to the cloud and open the PDF. Please note that the image in the report is a screenshot taken at the moment when 'Make Report' is clicked. It is therefore important to be aware that the screen displays the measured area if you want to have the correct area shown in the report.

4.5.6. Exiting Infield Design

To exit the Infield Design click the *Exit Infield* -button or the Infield Design icon at the bottom of the screen.

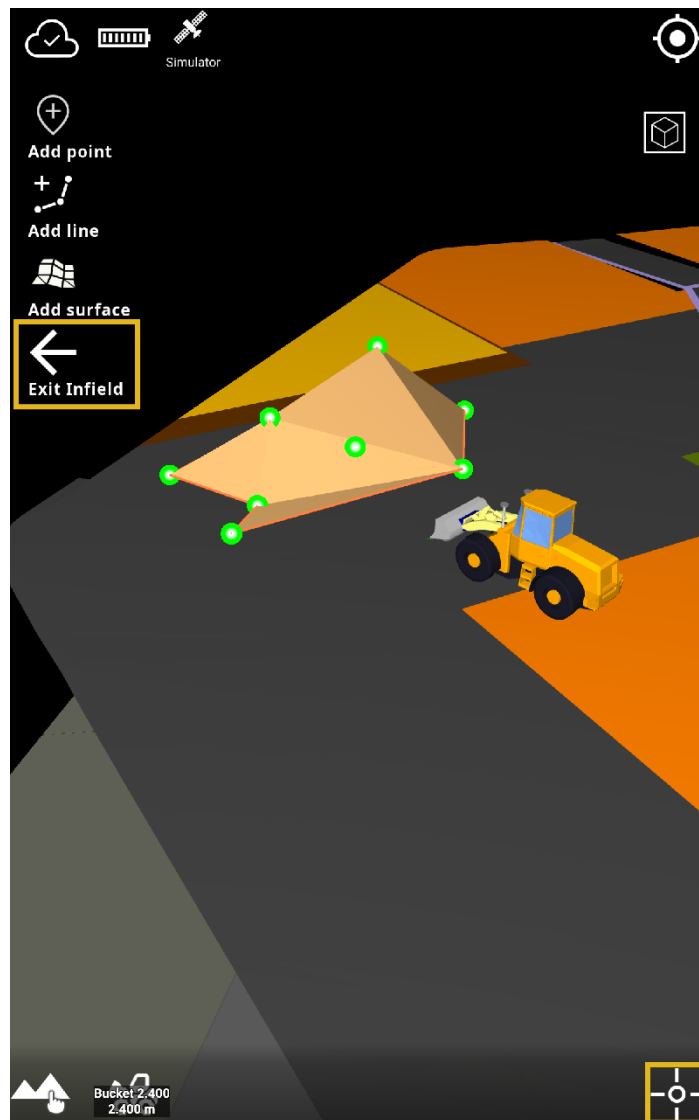

4.6. Geodetic systems

Only in rare cases should the machine operator be concerned about selecting the correct coordinate system and geodetic model. With Makin' 3D these matters are handled in a central place - e.g., the construction office. When made available, the geodetic system cannot be changed on the excavator. It is possible though, to handle the geodetic system locally when required by simply not having it preselected for a particular project.

4.7. Extend surface

Extending the surface allows you to continue your excavation even if you are beyond the design that is already at hand. By selecting '**Extend surface**', you extend the road surface you are working on - even if the actual design has limitations. The same is true for cuts where the cutting surface is too short for you to find the cutting top.

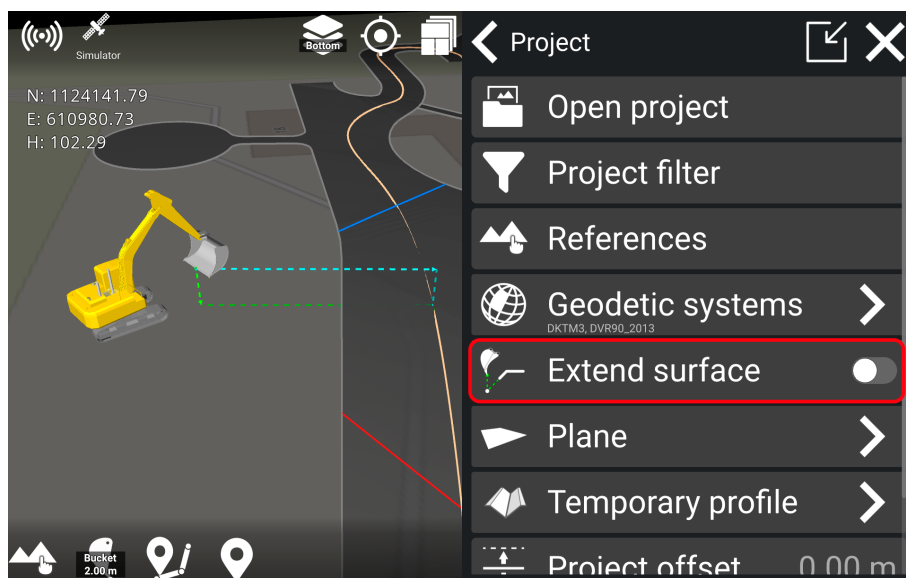

The way the surface extends depends on the file format you are using:

Road formats: For road formats like road lines and xml. files, the surface will extend perpendicular to the centerline when you select 'Extend surface'.

Other formats: For surfaces with other formats like dxf. and landxml. the surfaces will extend with a heading cut across, when using the feature 'Extend surface'. It means that the extended line will move along with the bucket's cutting edge.

Note that when you extend the surface, only the current tool point's height will be shown when you are beyond the design. Only one height will be calculated, which will be the height from the active tool point.

Extend surface using road formats:

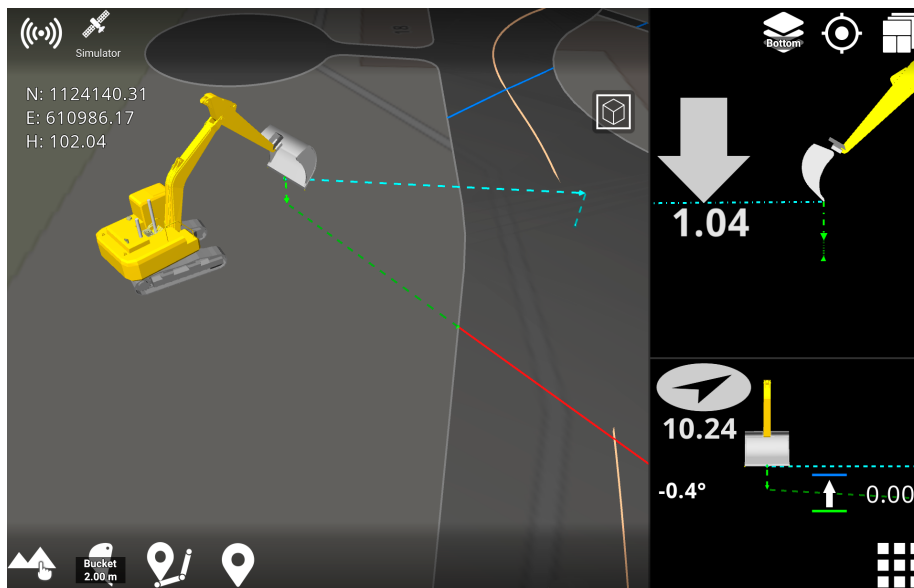

Extend surface using other formats:

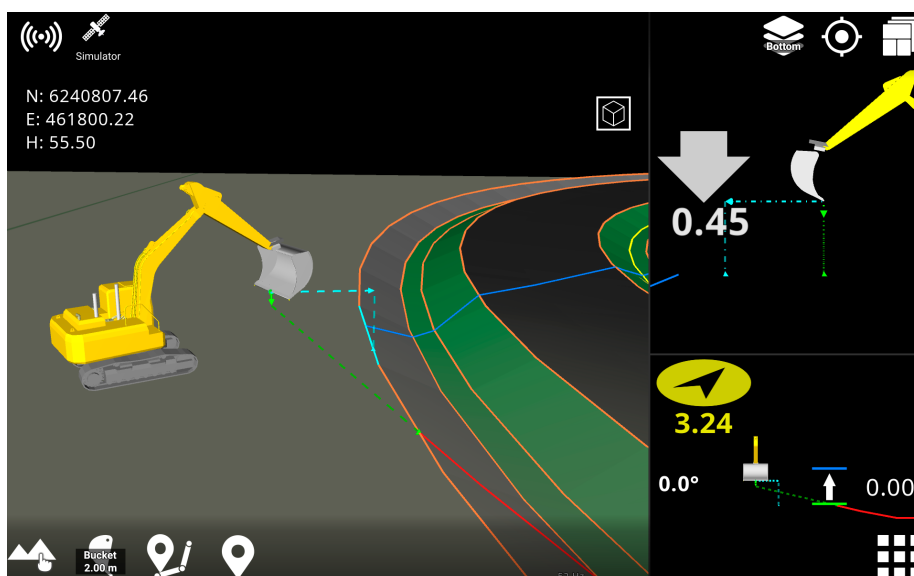

4.8. Plane

By activating the '**Plane**' feature, you get a virtual reference plane, which can be either flat or sloping with a 1-sided or 2-sided fall.

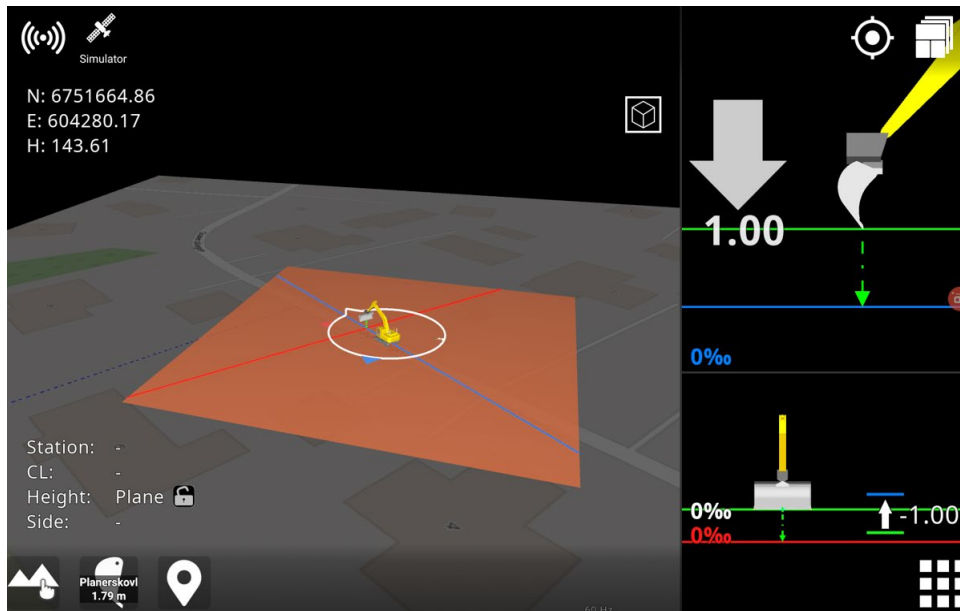

Use '**Main direction**' and '**Main slope**' to indicate the plane's longitudinal direction and angle. Likewise, set the transverse slope of the plane with '**Side slope**'.

With the '**Elevation**' option, specify the absolute elevation height or quickly get the current height of the tool point. Another option, called '**Set plane here**', also uses the current tool point height, but with the addition of taking the reference height offset into account.

When the plane is active, you can tap the visual part of the plane to quickly change its values. When you no longer need this feature, it is important to disable the plane. If you do not do this, the activated plane will follow the machine wherever it may be located.

Tap to activate and deactivate a virtual plane and change the longitudinal direction, longitudinal slope, and transverse slope.

If you set the height manually and then enter a longitudinal fall, the point for starting the slope will still be below the "cross thread", which forms the center of the measuring point on the bucket. Those are the E and N coordinates that you can see in the upper left corner. It is important to keep in mind that the measuring point on the bucket is above the desired starting point for length/cross slope.

4.9. Temporary profile

Toggling the **'Profile'** option turns the temporary profile on or off while its settings are retained.

There are two options for moving the profile, respectively **'Set profile here'** and **'Set profile & direction here'**. The first option horizontally displaces the profile and positions the middle of its centerline at the tool point. In addition, the latter option also rotates the profile according to the heading of the bucket/attachment.

Adjusting the **'Slope'** will tilt the profile along its baseline.

Under **'Edit profile'** you can change the profile's contours by adding and removing surfaces as well as changing the width and slope of the surfaces. Changing slopes can be done either by specifying the height difference between two surfaces or by specifying the percentage slope between them. Also, you can specify a height offset for the profile, where the baseline is indicated by a gray line in the 3D view.



The profile can be rotated by using **'Edit direction'**. North corresponding to 0 (zero) degrees. The feature **'Get direction from tool'** will align the profile according to the bucket/attachment.

As an alternative to going via the menu, you can jump to this feature by tapping the profile in the 3D view.

4.10. Project offset

Project offset is designed to adjust a machine's height to match the height of the design project you are working on. Even if a machine is correctly calibrated, the height measured by the tool point in the application can differ from the height of a known point on the project. These differences can occur as a result of differing reference systems, e.g.: localized coordinate projections vs. official coordinate projections. Other sources include small variations between GNSS manufacturers as well as incorrect heights used in the initial project design.

To mitigate this, we have added the project offset functionality, which adjusts the received GNSS height (not the antenna height) to match the height of the known point on the project.

Note:

You must ensure that the machine is calibrated correctly before adjusting the project offset. Project offset is limited to adjustments of +/- 50 cm.

Project offset can be adjusted in: *Main Menu > Project > Project offset*

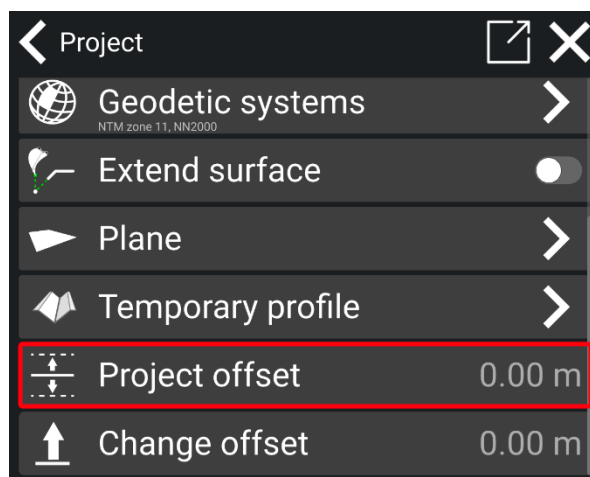

How to use:

- 1) Inside the project offset menu, you will see the tool point height of your application in the value area.

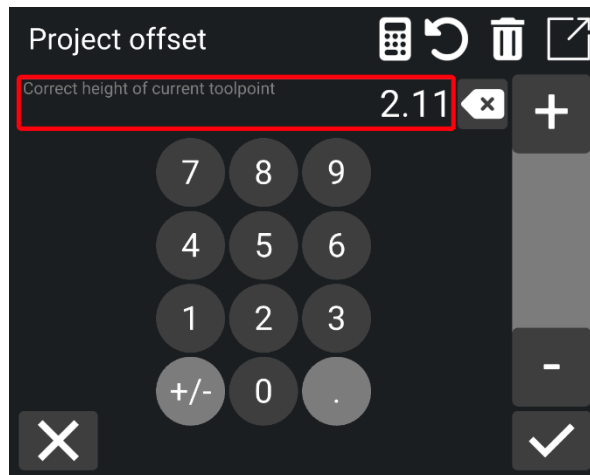

- 2) Enter the correct height of the known point in the value area to calculate a project offset.
- 3) It is also possible to adjust the project offset using the +/- buttons, increasing or decreasing the value by 1 cm per tap.
- 4) A project offset is calculated and visible in the project menu. When you have a project offset, the icon will be visible on the work screen.



To remove the project offset, go into the **Project Offset menu** and tap the **trash can icon**.

4.11. Change offset

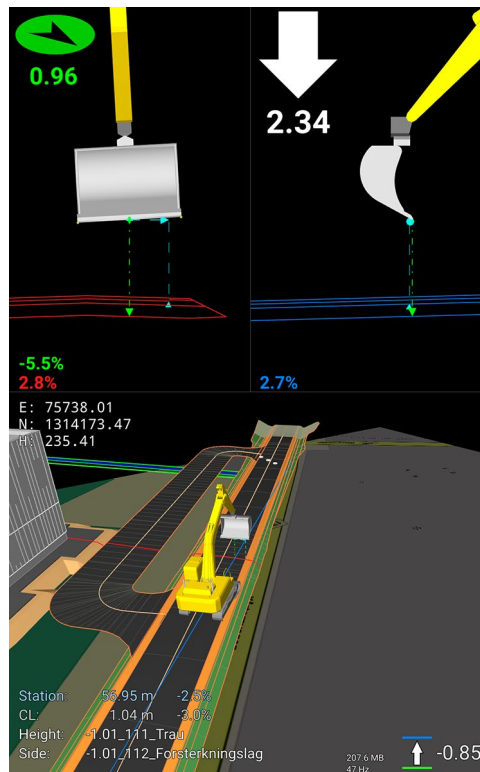

Entering this menu adjusts the height offset you want to have for the whole project. Typical uses are where you have only been given the surface of a road and should dig for a ditch or other layers beneath the surface. If the ditch is known to be 0.85 meters under the finished road, then adjust the offset value to -0.85. A parallel surface/line will then be created 0.85 meters beneath the theoretical model. The whole model will be offset.

You can enter the desired value manually or move your finger up or down in the vertical field.

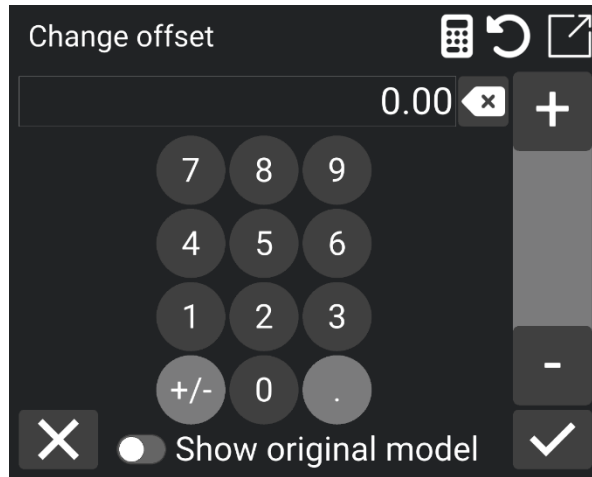

If you have applied an offset but want to view the model with its original offset, enable '**Show Original Model**'.

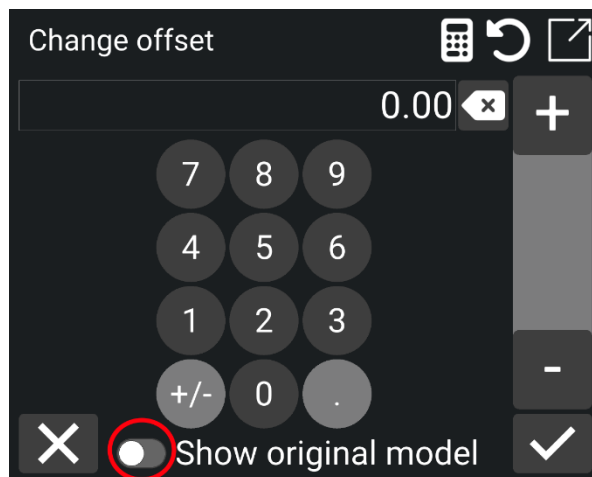

5. Display

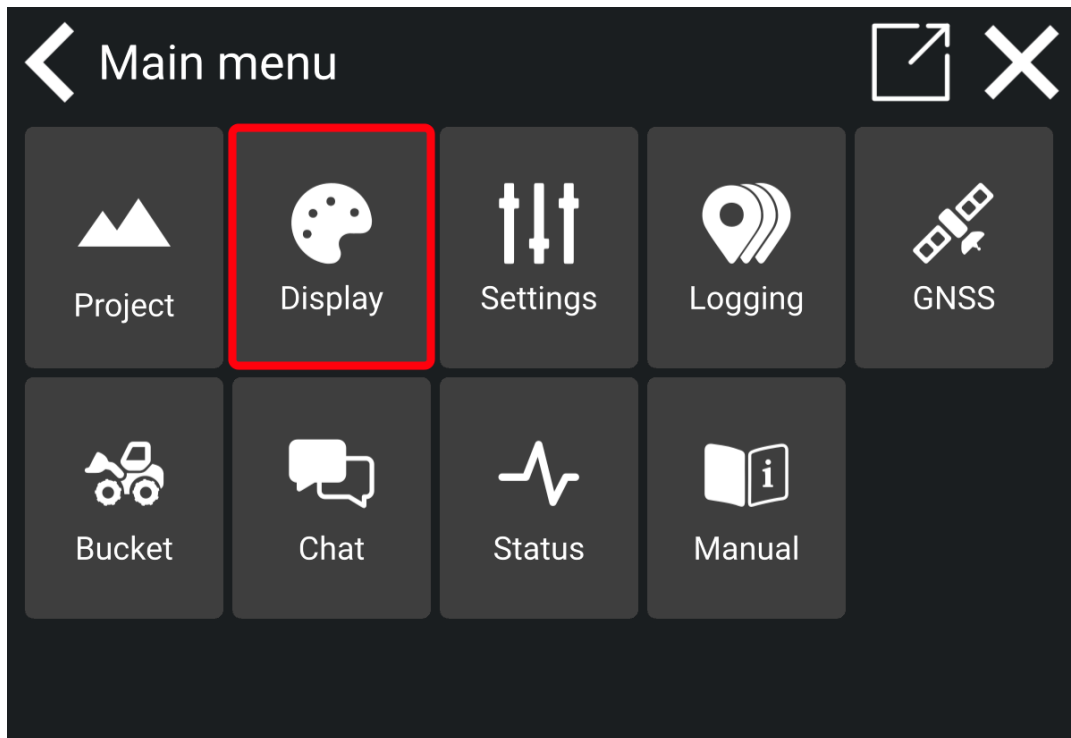

5.1. Labels

A label is the name of a geometry object of the following type:

- Points
- Lines
- Surfaces
- Stations
- Log Points
- Log Objects
- Texts

It is possible to choose which type of label should be visible by selecting/deselecting it on the list.

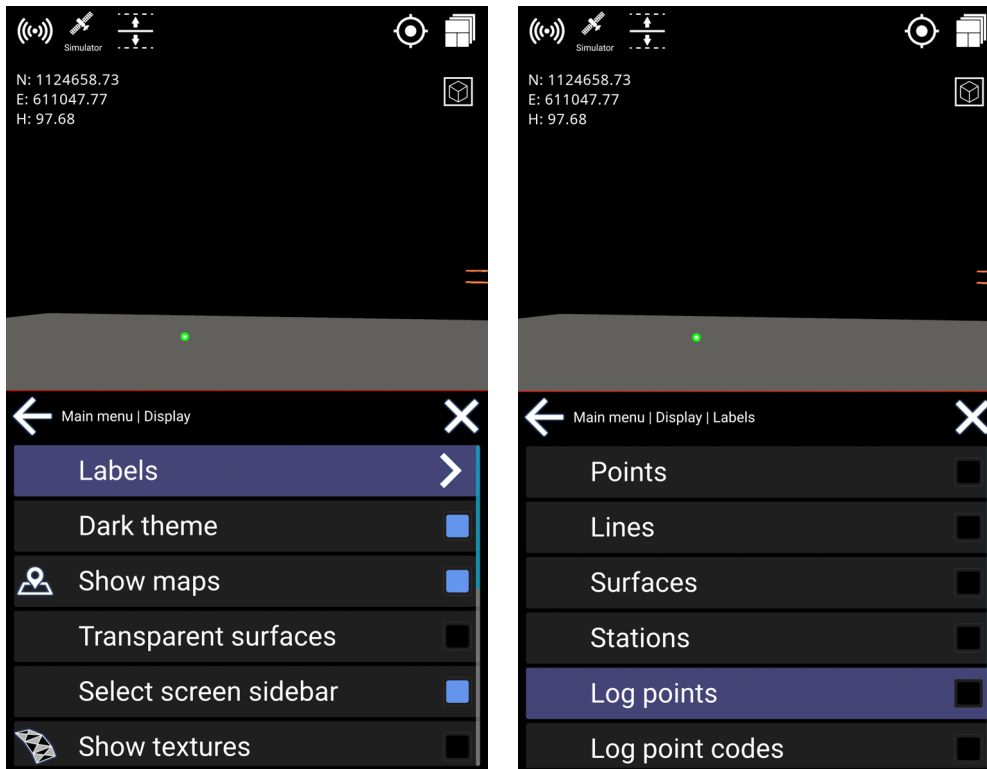

5.2. Screen indicators

It is possible to hide some of the screen indicators in the work screen area. This function is designed to let you remove non-essential features, that could be distracting on the screen.

With all screen indicators:



With selected screen indicators:



5.3. Use file color

This feature changes between using the colors stored on file or the default color scheme of Makin' 3D. In some situations, it gives a better overview using the colors of the model file and will make it easier to separate elements in a complex file.

If file color is not enabled, Makin' 3D will use default colors.

Be aware that some files can include black-colored lines or designs, and these will not be visible if the file color is selected.

- Tap to select/deselect file colors

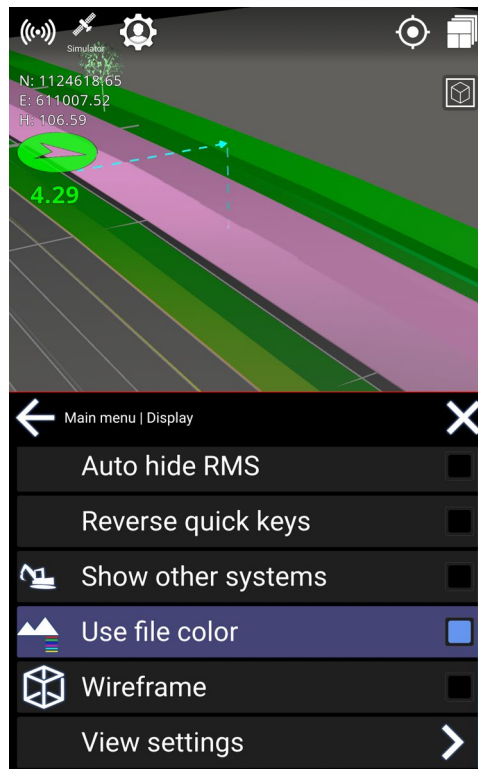

5.4. Show maps

The user can hide or show maps along with the project to get a better overview. The map will be shown below the lowest active 3D reference in the project.

The tool cuts are shown on the map in Top View. Otherwise, tool cuts are only shown on elements of the 3D model marked as a height reference.

Note: In the 3D View, the map will be seen in a perspective view. If you want to see it straight from above, use the Top View instead.

- Tap to select/deselect visibility of map

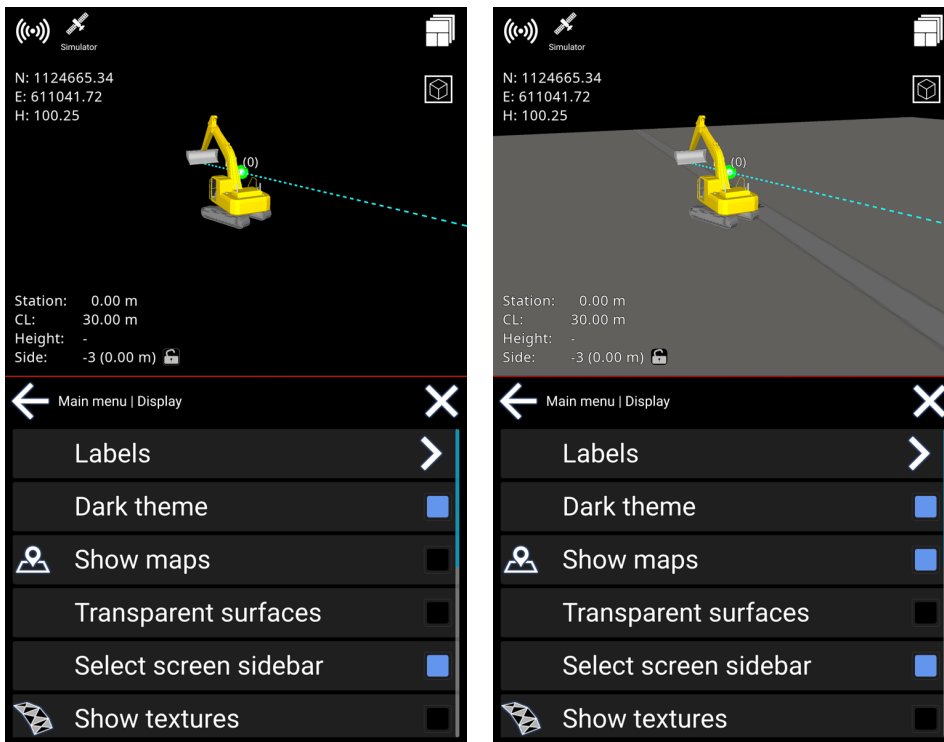

5.5. Show other systems

Other systems currently working on the same project—like machines, rovers, etc.—will show up.

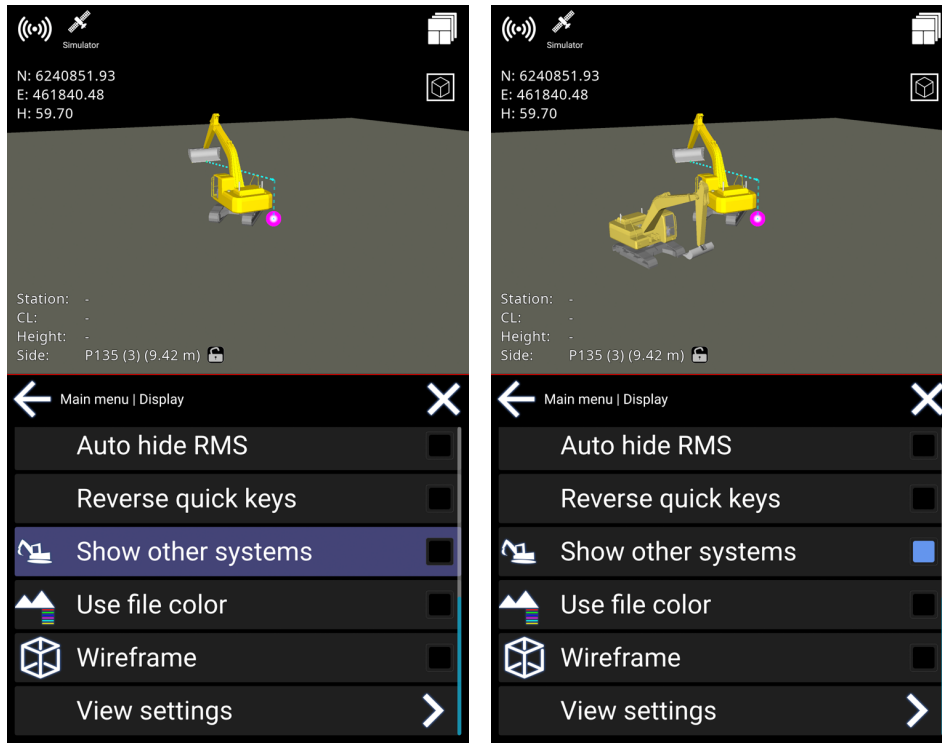

5.6. Show textures

Instead of using solid colors, you can have textures shown. This is only possible with road geometry.

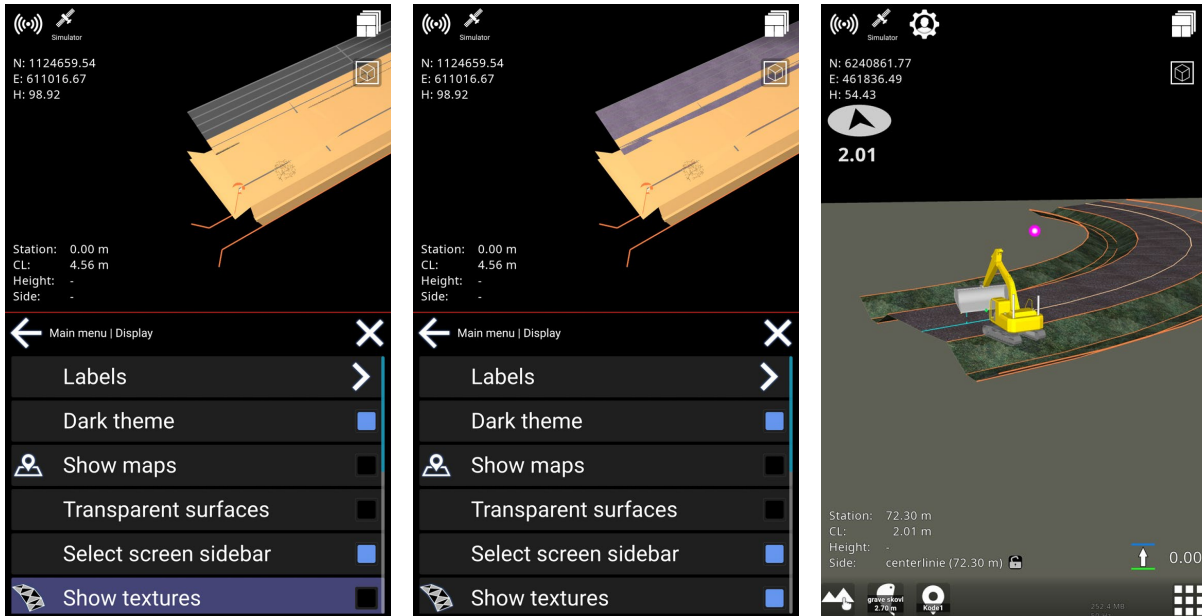

5.7. Tool point coordinates

You have the option to show or hide the tool point coordinates in the app. When activated, the coordinates for north and east will be displayed along with the height. If deactivated, only the height will be shown.

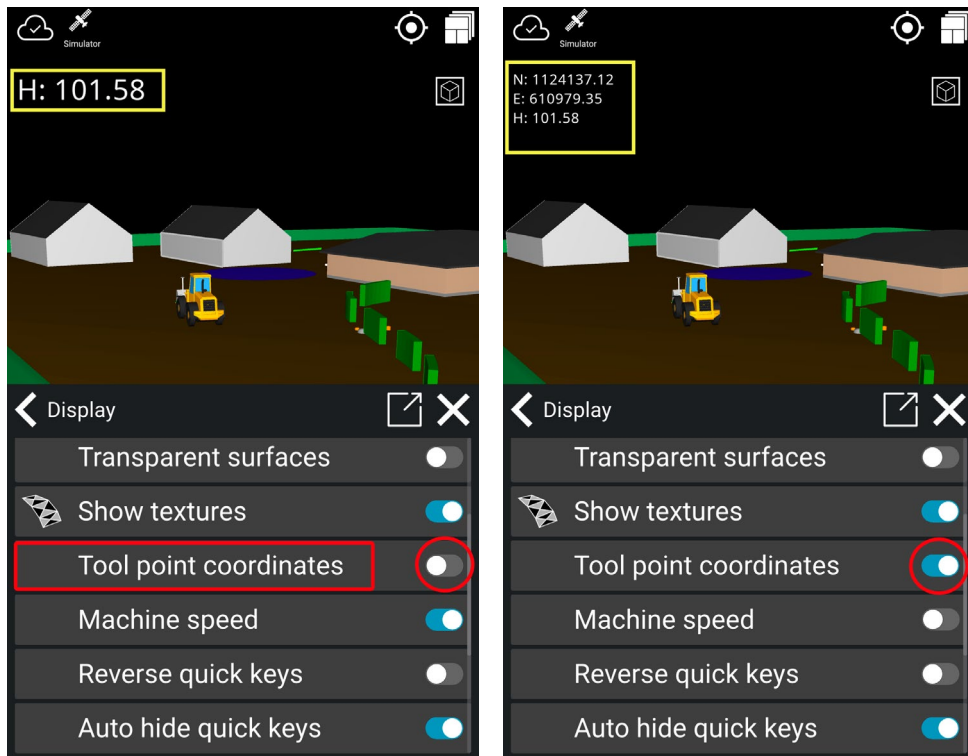

5.8. Machine speed

This feature '**Machine speed**' shows the speed of the machine, working like a speedometer. The speed is displayed in kilometers per hour (km/h). When activated, the speed will appear in the top left corner.

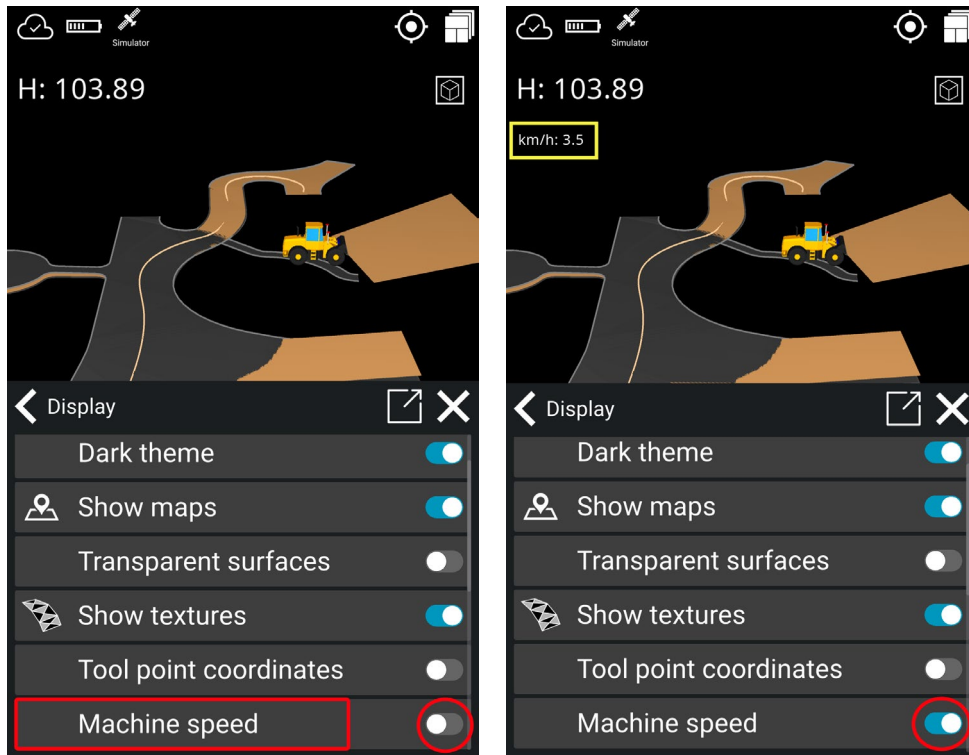

5.9. Auto hide quick keys

Auto Hide Quick Keys will hide the “quick keys” at the bottom of the screen after about 8 seconds of not touching the display.

When you touch the display, they become visible again. It will give you a clearer view of what you are working on when icons are hidden.

5.10. Reverse quick keys

This feature places the quick keys to the right of the menu button. It makes it more convenient to log points from the right-hand side of the screen without having to visually locate the point logging feature.

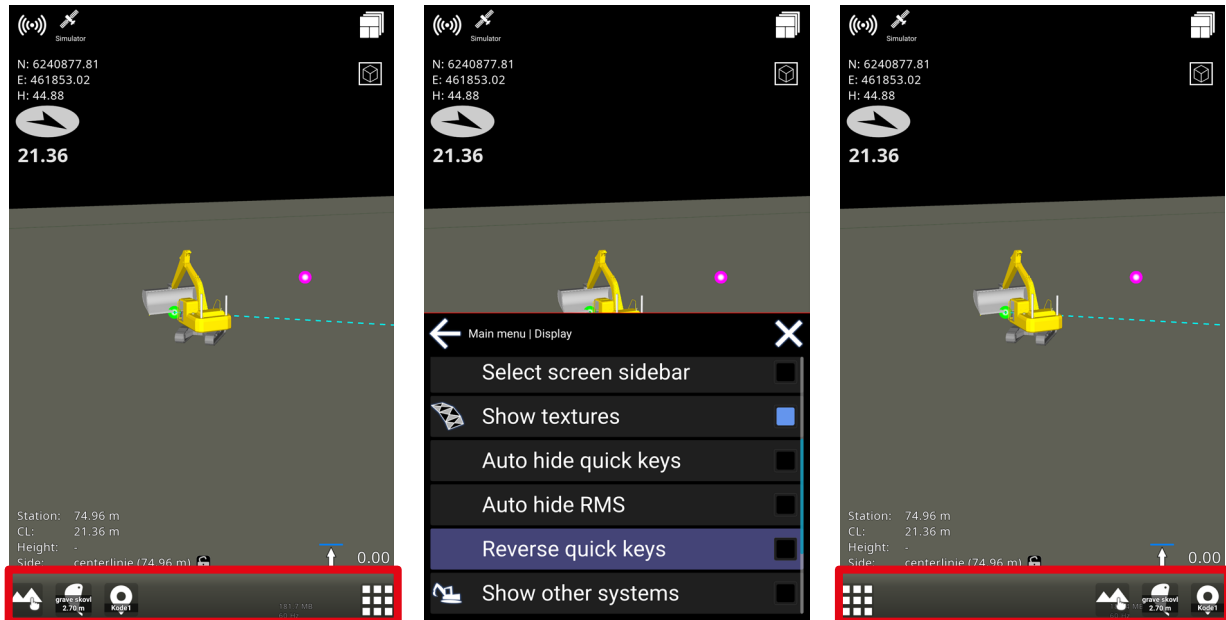

5.11. Transparent surfaces

Hide the surfaces to be able to see lines and points beneath them.

Note: Surfaces with textures will not be transparent.

Warning: Reference selection is not visible when transparent surfaces are enabled.

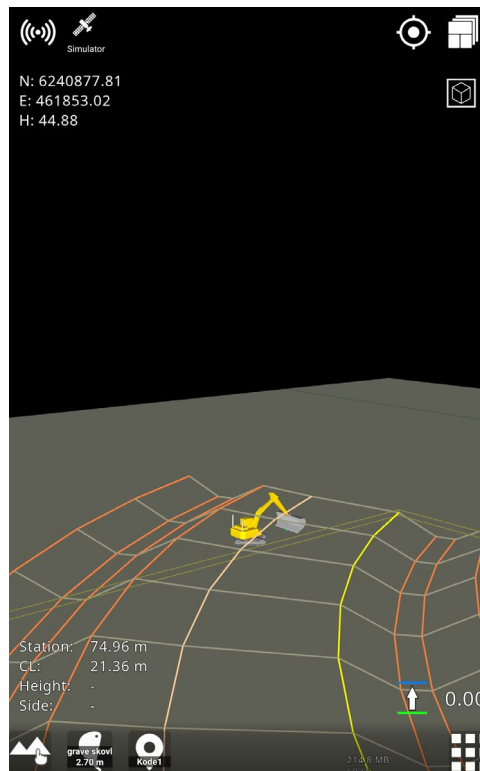

5.12. Dark theme

By default, the machine control system has the 'Dark theme' enabled, which is great at night time or when working in dimmed conditions. It is recommended to disable this feature when working in a bright environment, especially while working in direct sunlight when staking out points outside the cabin, etc.

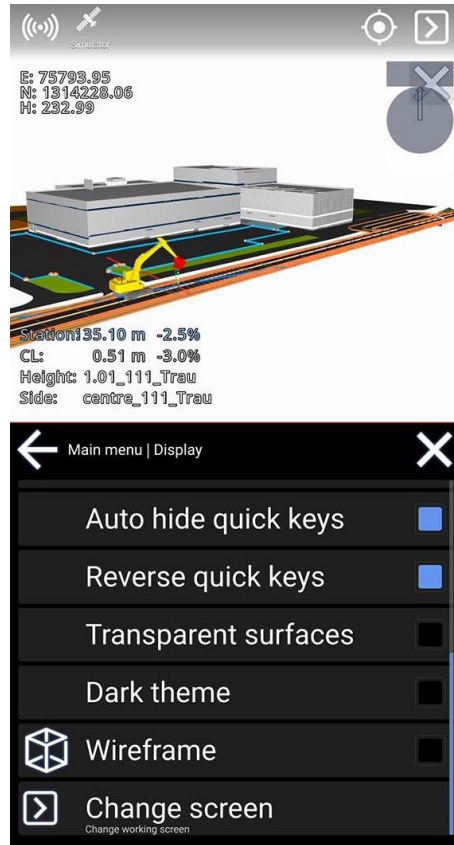
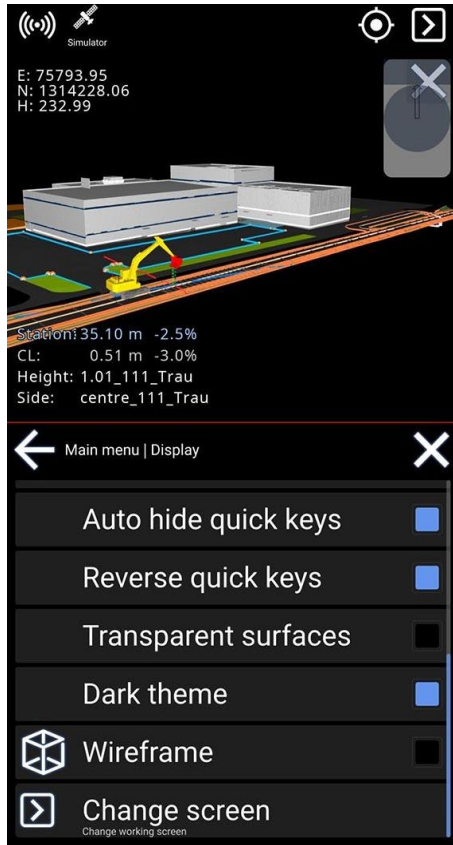

5.13. Wireframe

Tap **Wireframe** to enable the triangular design to be visible. This will show the edges of the triangles and might improve their visibility.

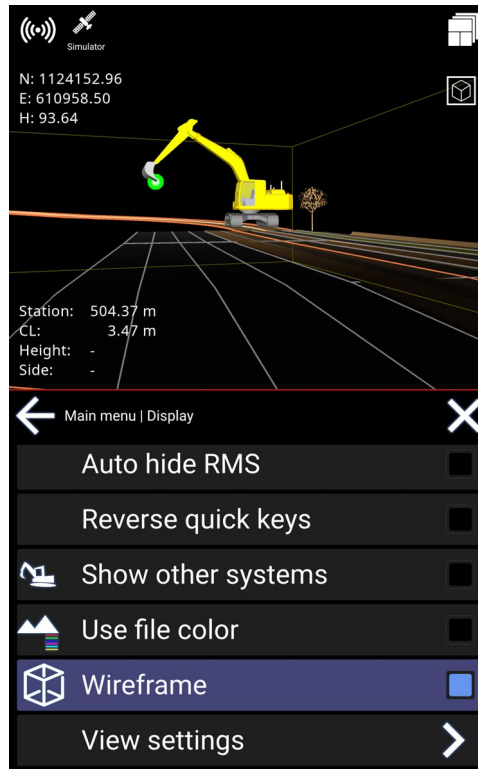

5.14. View settings

To obtain a better overview of your work, you now have the option of hiding the excavator or making it transparent.

Open the menu and select **Display**. Scroll down to **View settings**.

It is possible to set this individually for a work situation or when you touch the screen. You can also choose individual settings for work screens with 3D View or Top View.

You can now easily toggle between 3D View and Top View by pressing the icon in the upper right corner.

Menu > Display > View settings > Top view

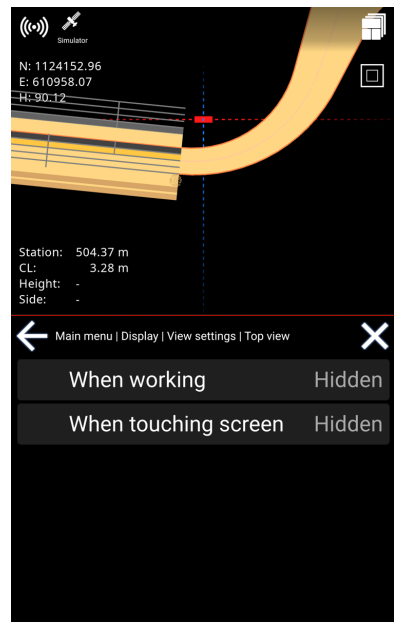
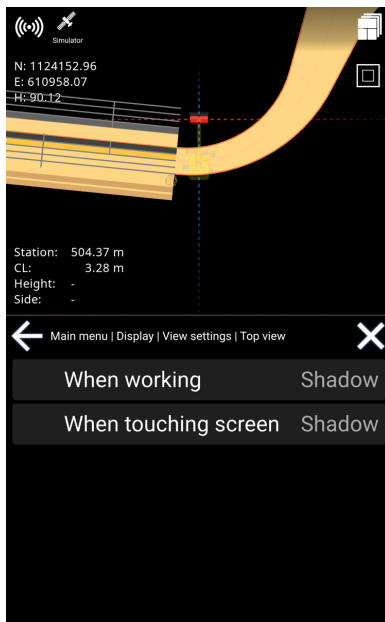
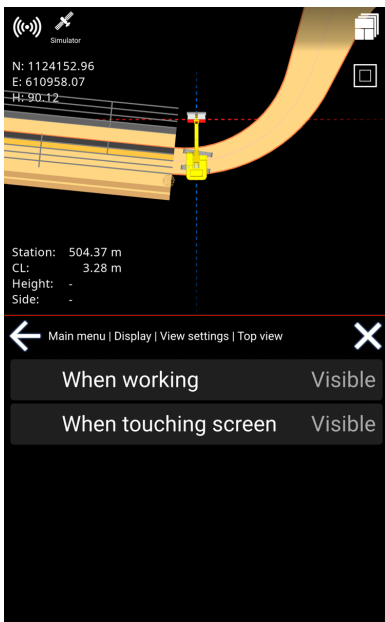

Menu > Display > View settings > 3D view

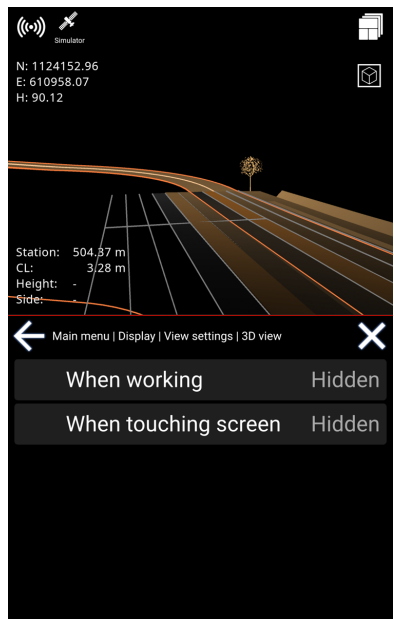
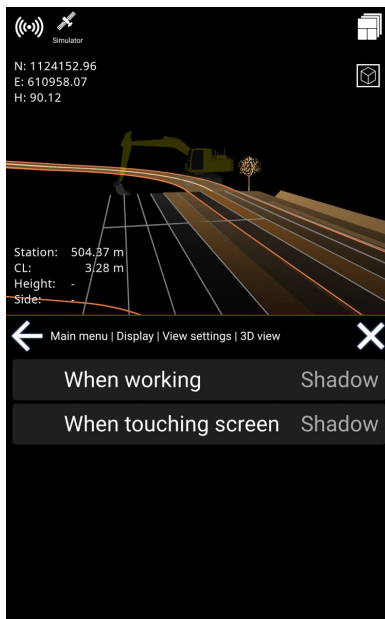
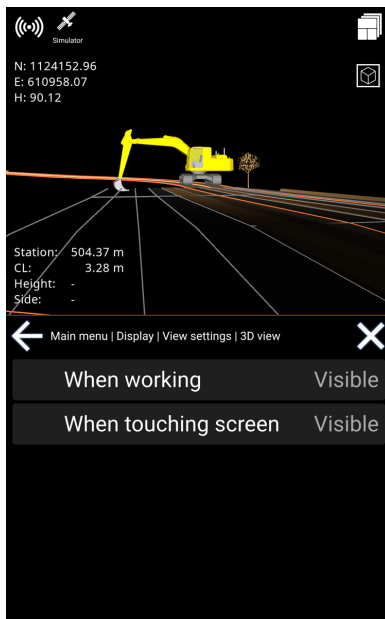

5.15. Change screen

This option is to change the working screen. Tap the icon in the top right corner and select the work screen option you want to display.

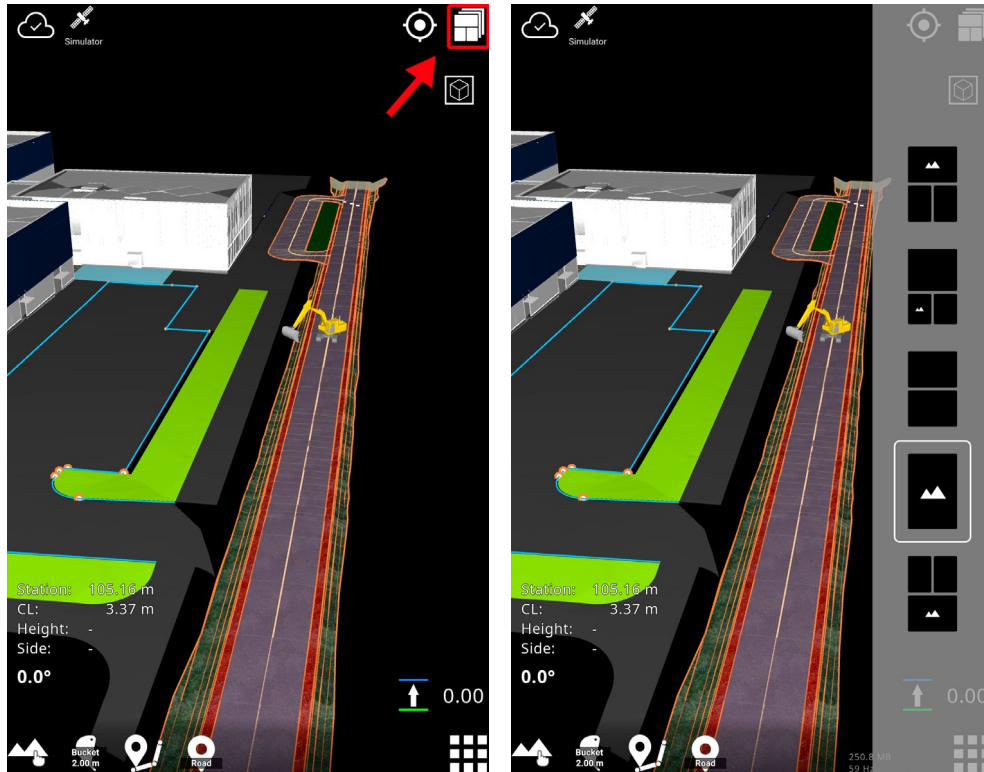

6. Settings

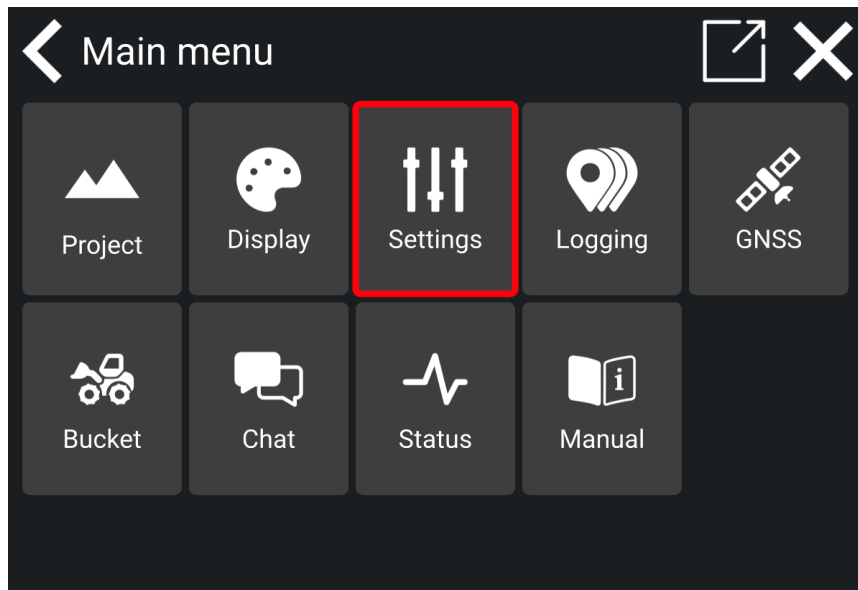

6.1. Tolerances

Tolerances are thresholds for calculations. They are used for different indications, like colors and sounds. You can change the tolerances for height, side, and alert.

When working outside the specified tolerances, the indicator in question is shown in white color.

6.1.1. Height tolerances

1) Tap 'Height'.

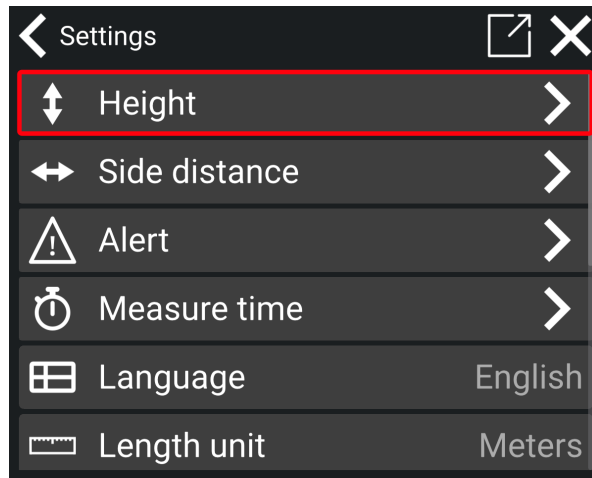

2) Tap 'Height tolerance'.

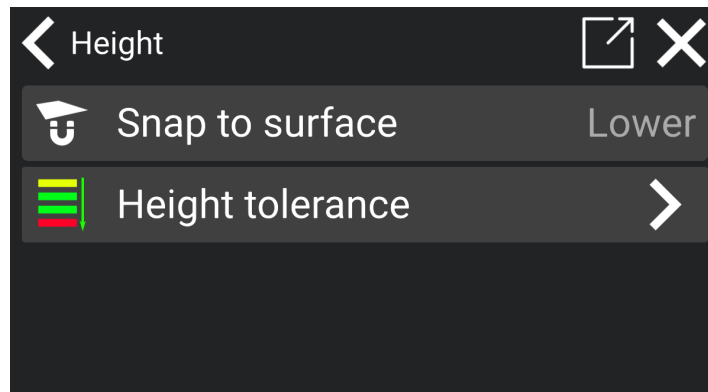

3) Choose any of the 3 options (Red, Yellow, Green).

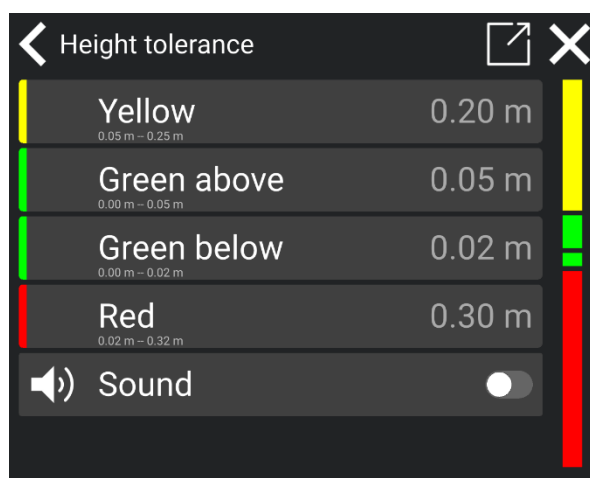

4) Enter the tolerance.

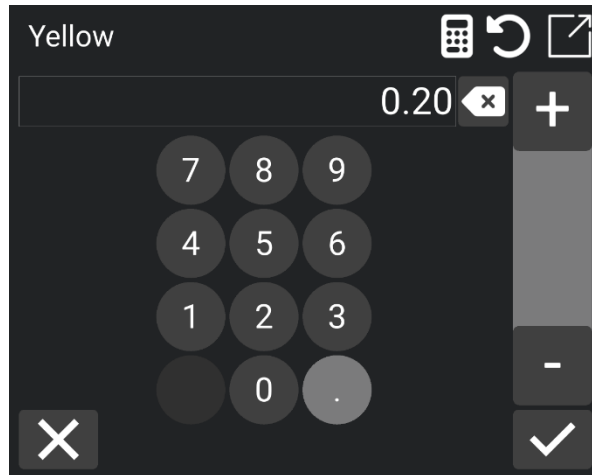

The 'Yellow' band for the height tolerance indicates a distance for when to start showing that you are near a selected height reference.

'Green above' and 'Green below' are the limits for the accepted height deviation, respectively above and below the reference. As long as your measurements fall within these green zones, the deviation is within the allowed range, and the job meets the required standards.

'Red' is an indication of excavating too deeply into the ground. The tolerance is an expression for when to ignore the warning when you are far below the reference.

The sound option will enable different sounds depending on the band within which you are working. There will be no sounds when working above the yellow band and below the red band.

6.1.1.1. Snap to surface

If you have multiple height references activated, you can select whether the tool point should snap to the lowest or the highest surface. This means that when height references for multiple layers are active, the tool point will automatically snap to either the lowest or the highest surface, depending on your chosen setting.

- 1) Go to *Settings > Height*.
- 2) Tap on 'Snap to surface'.

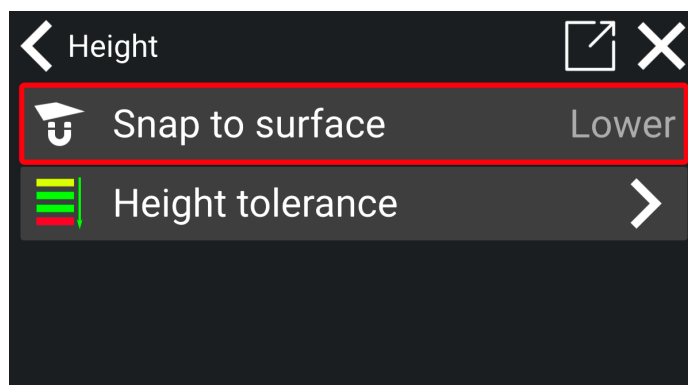

- 3) Choose between 'Lower' and 'Upper' to snap to the lowest or highest surface depending on your preference.

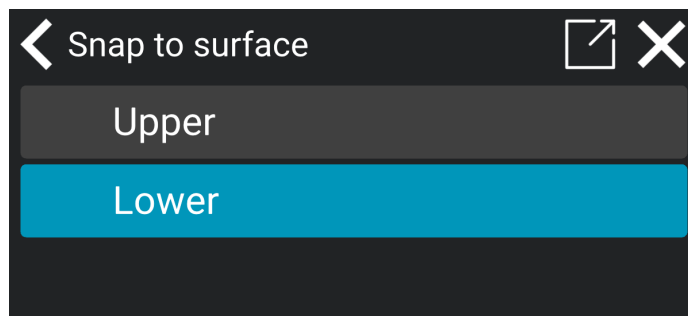

- 4) The tool point will now snap to the lowest or upper surface depending on your chosen setting.

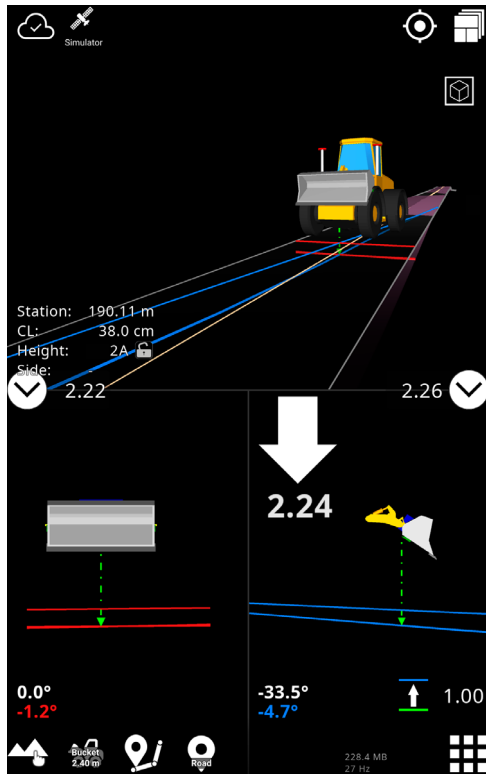

6.1.2. Side tolerances

For the side distance, 'Red' means that you are approximately within reach of your target, and 'Yellow' means that you are even closer. The 'Green' band indicates the accepted deviation from the target.

Keep in mind that the side distance is calculated horizontally and is not the shortest path.

1)

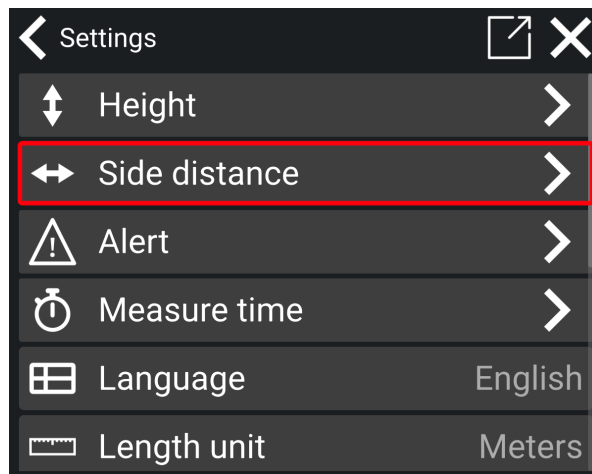

2)

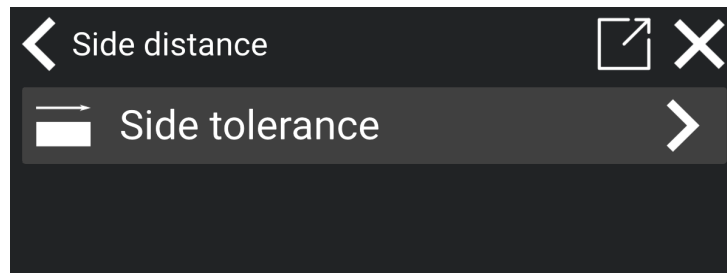

3) Choose any of the 3 options (Red, Yellow, Green).



4) Set the tolerance.

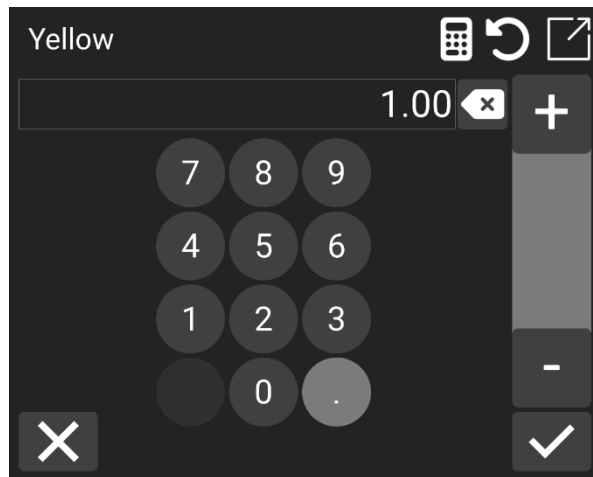

6.1.3. Alert tolerances

The tolerance for alert is divided into *Show*, *Warning*, and *Danger*.

- If you are in the 'Show area', a red 3D line will be shown.
- If you are in the 'Warning area' you will get a warning notification saying, "Too close".
- If you are in the 'Danger area' you will get a danger notification, and an alarm will sound if turned on.

1)

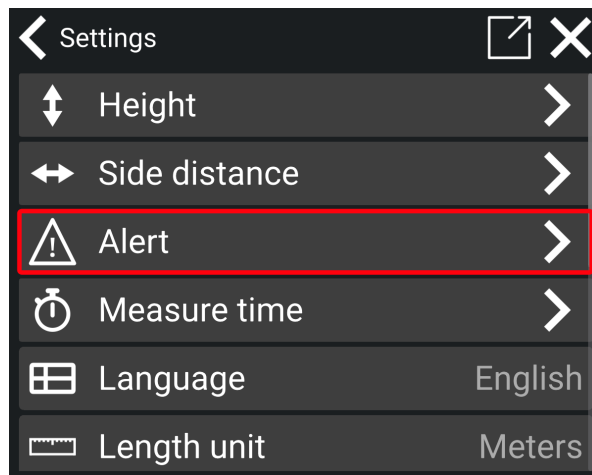

2)

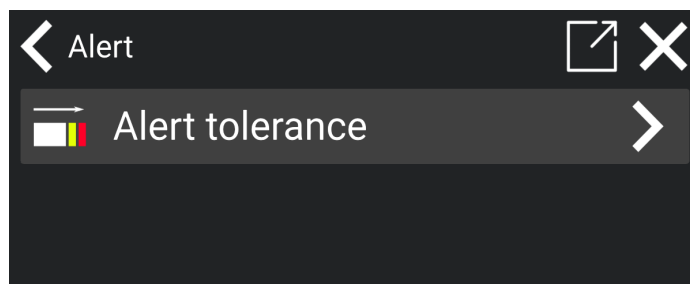

3) Choose any of the 3 options (Show, Warning, Danger)

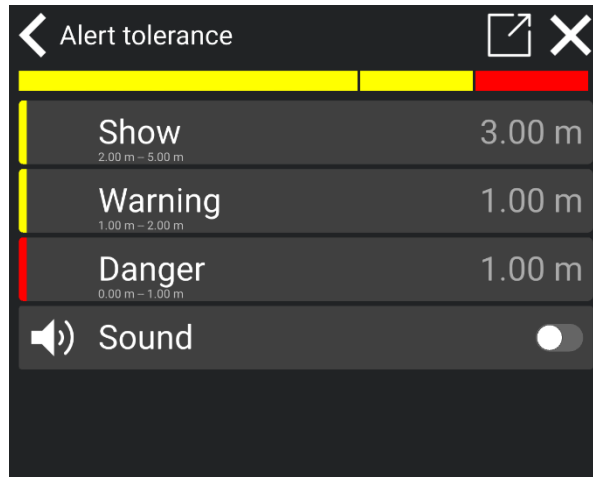

4) Change the distance you want from the point of alert.

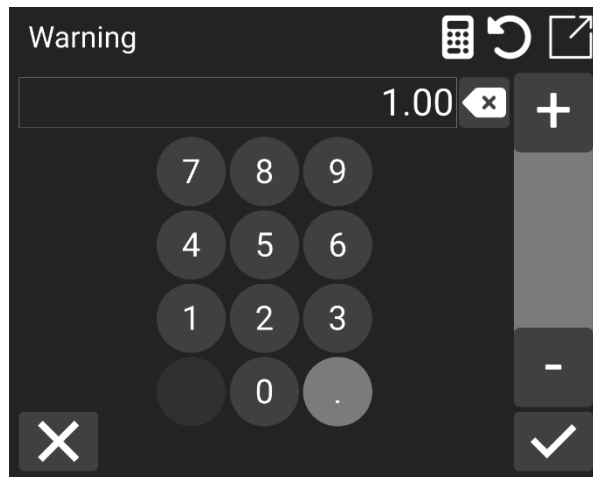

You will have a sound option as well. Activate the button for sound or deactivate it for mute sound.

6.2. Measure time

For the most accurate measurement in the Makin' 3D app, you can adjust the measured time settings. You can also improve accuracy by allowing the sensors to stabilize and reducing surrounding noise from GNSS by delaying the measure time.

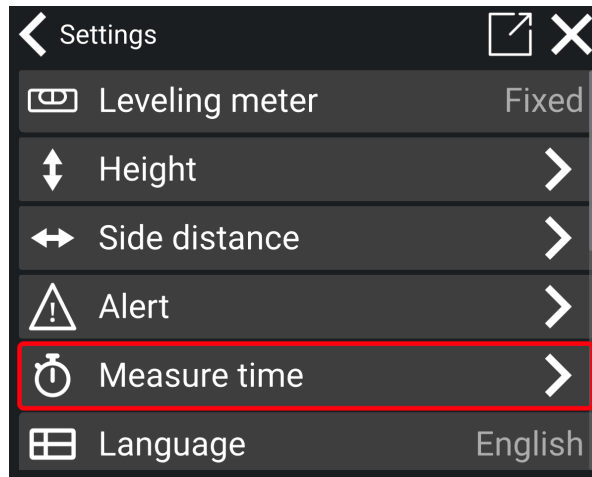

In the 'Measure time' menu, you will see two functions: **Measurement time** and **Delay time**. These settings allow you to fine-tune the measurement process for the most precise results. Learn more about how to use these settings in the following paragraphs.

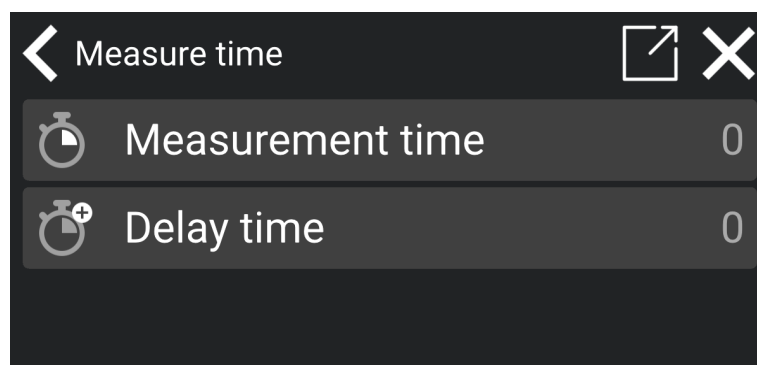

6.2.1. Measurement time

When you use the 'Measurement time' function, you can specify a duration for the Makin' 3D app to measure. This feature accounts for GNSS fluctuations by averaging the data for greater accuracy. For instance, if you set the measurement time to 1 minute, the app will calculate the average position after one minute for a more precise reading.

- 1) Tap on **Measurement time**.

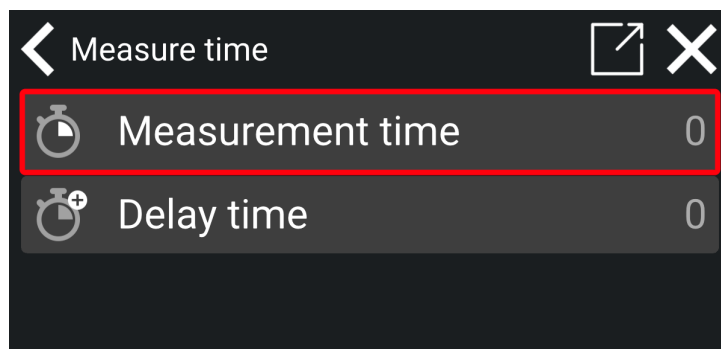

- 2) Set your desired measurement time.

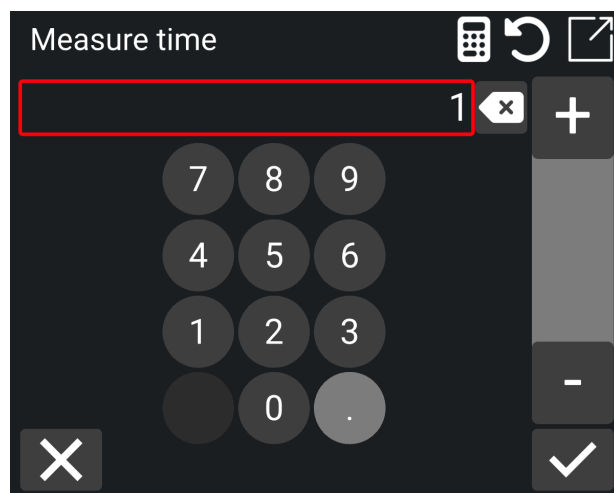

- 3) Tap on the check mark to save.

6.2.2. Delay time

With the 'Delay time' function, you have the option to postpone the measurement process in the app. This delay allows the sensors to stabilize before capturing your position, leading to more accurate results. For instance, setting a 2-minute delay means the app waits for 2 minutes before starting to measure your position.

- 1) Tap on **Delay time**.

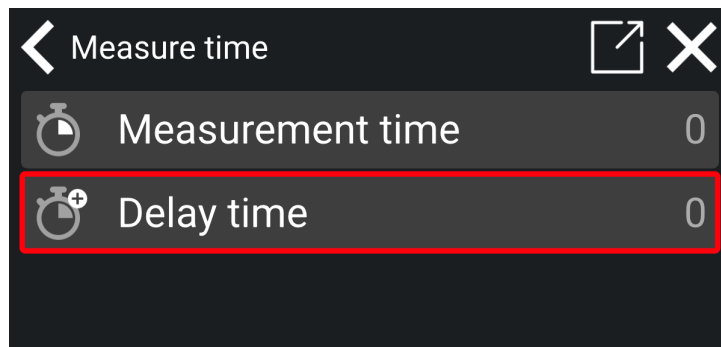

- 2) Set the desired delay time.

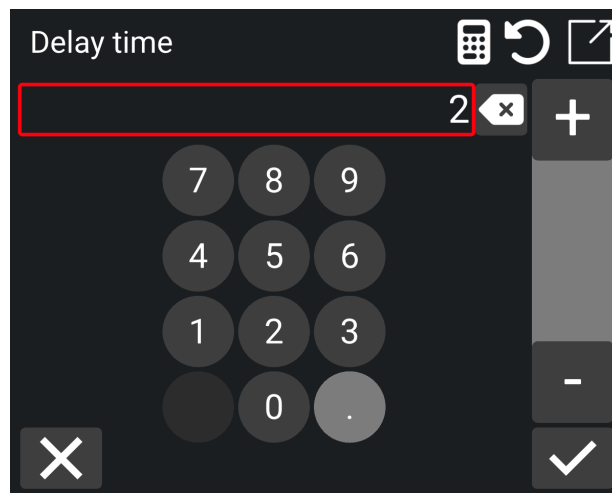

- 3) Tap on the check mark to save your selection.

6.3. Language

Select the language of your choice. The language is automatically changed and saved.

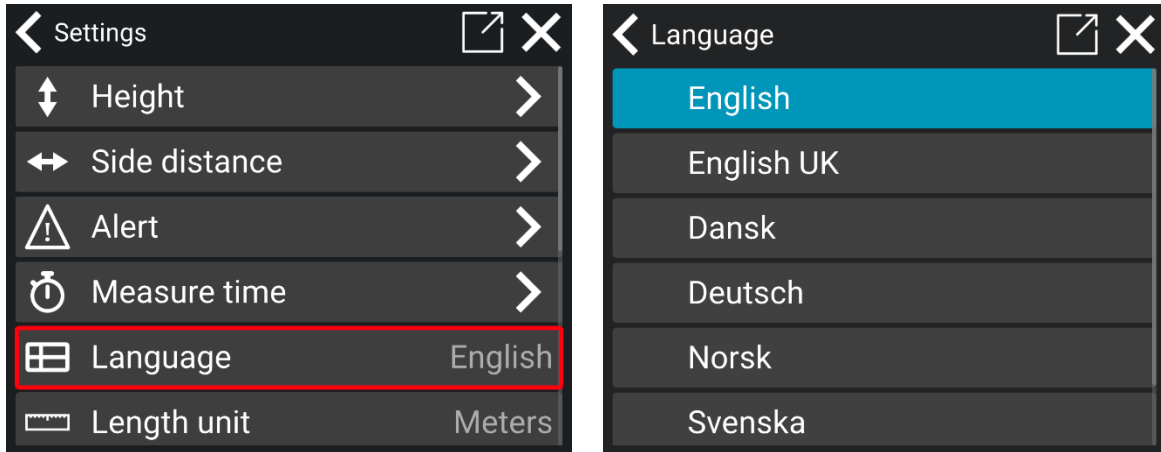

6.4. Length unit

Tap to choose the length unit. It is automatically changed and saved.

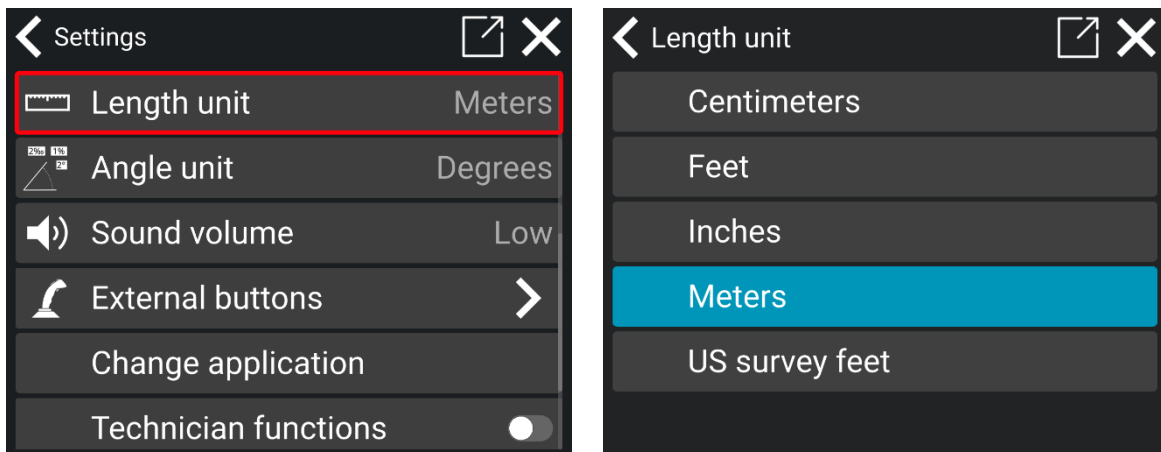

6.5. Angle unit

Tap to choose the angle unit. The angle unit is automatically changed and saved.

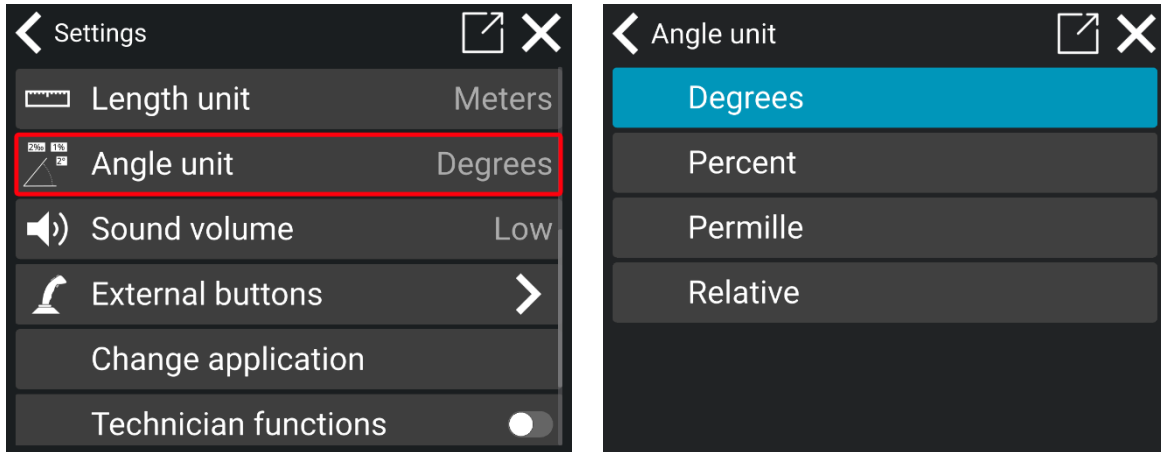

6.6. Sound Volume

Tap the sound volume again and again to change the sound level. Choices are given: *Low, Medium, High, Highest*.

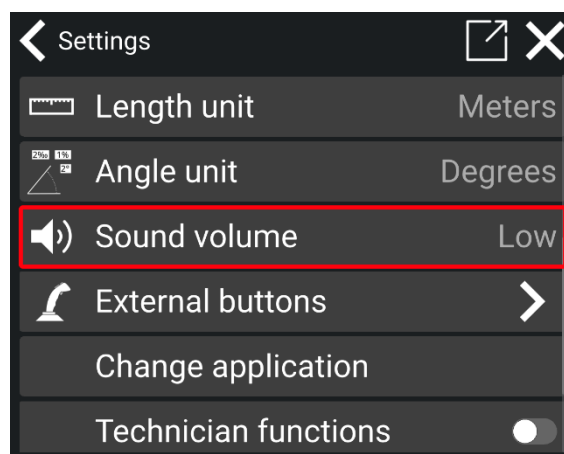

6.7. Area selection

The 'Area selection' feature makes selecting objects in areas with many elements (such as points, lines, or surfaces) easier. When you tap on an area with multiple elements, a list of up to 7 nearby objects will appear on the screen, which you can choose from by tapping on the object you want to select. The objects listed are the ones closest to the spot you have most recently tapped. A ring will briefly appear on the screen to indicate the area you are selecting.

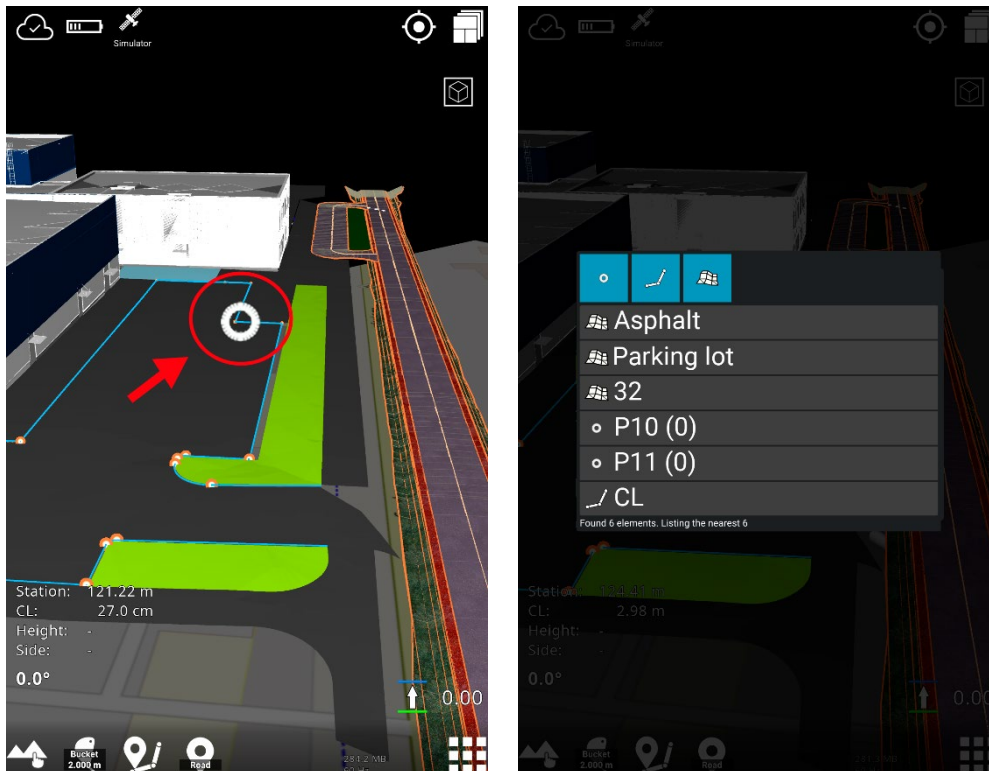

You can enable or disable this feature in the **Settings** menu. When 'Area selection' is disabled, only one object will be selected when you tap on the screen.

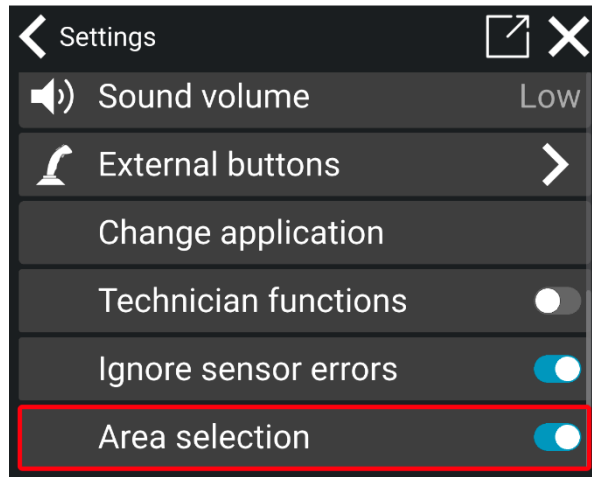

6.8. Leveling meter

In the Leveling meter menu, it is possible to turn on or off the height indicator on corner tool points.

It is possible to select between *Fixed* or *Moving* arrows.

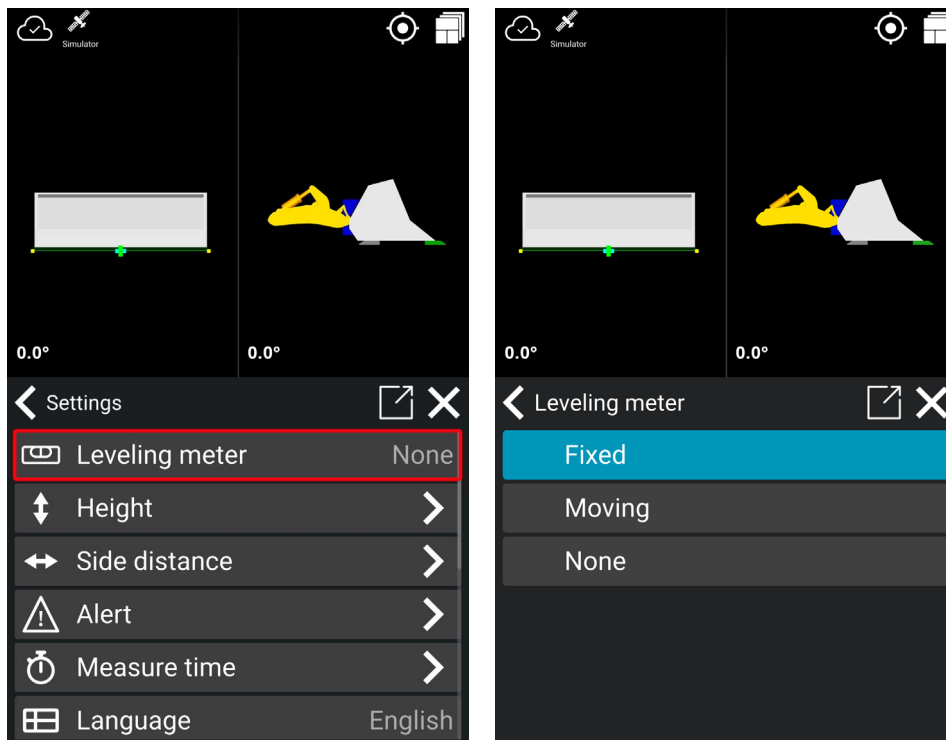

The green bars indicate the surface below the bucket when the plane has been selected.

The arrows and numbers in the circles indicate how far and in what direction you should move the bucket to match the surface below.

Fixed

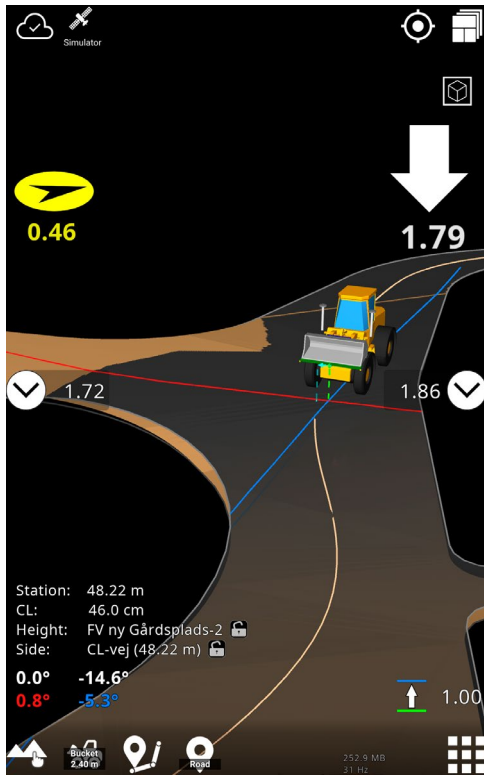

Moving

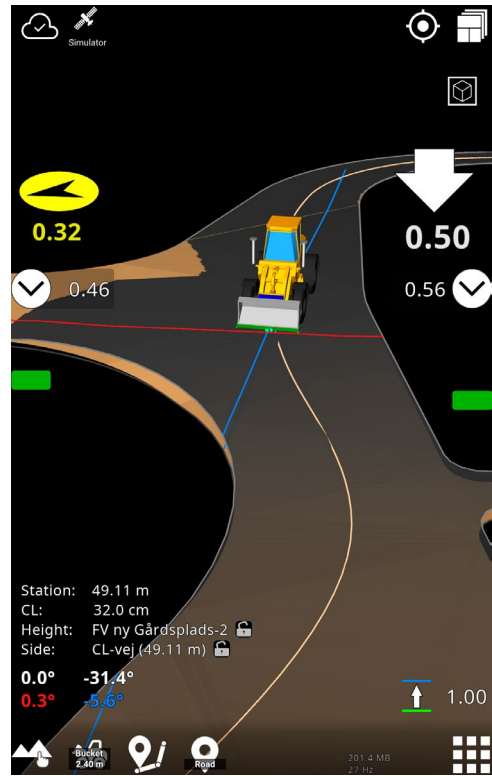

7. Logging (As-built)

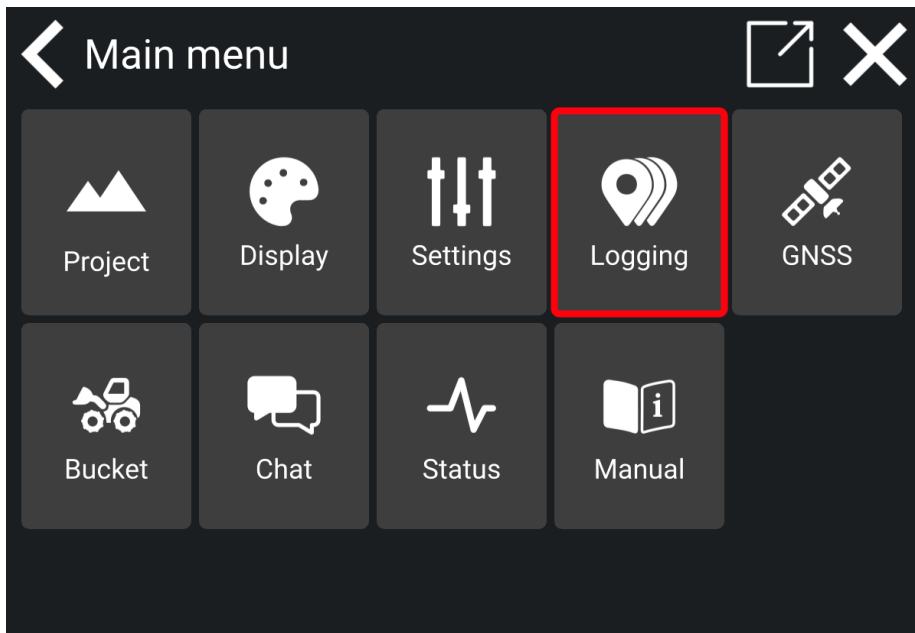

7.1. Log Point

Log Point is an as-built feature used to document points. You can access it from the Logging menu or by long-pressing the shortcut on the work screen.

Option A

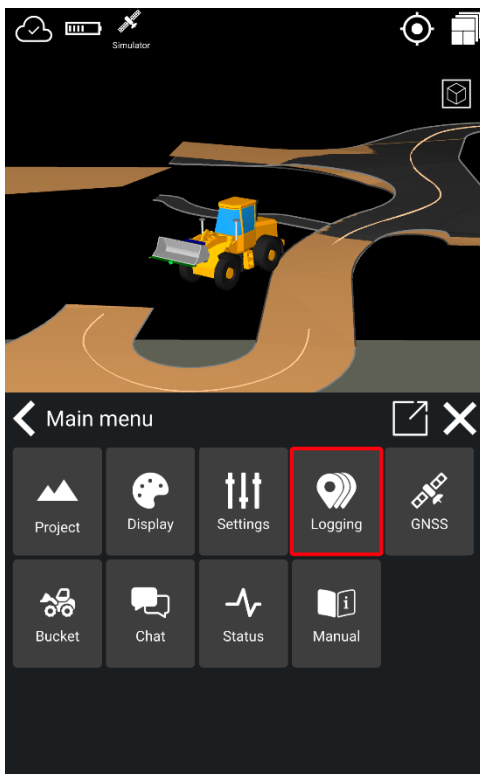

Option B



- 1) Tap '**Object**'. A list of your most recently used objects will appear.

If no objects are shown, click the **folder icon**, then select a group of objects to find the one you need.

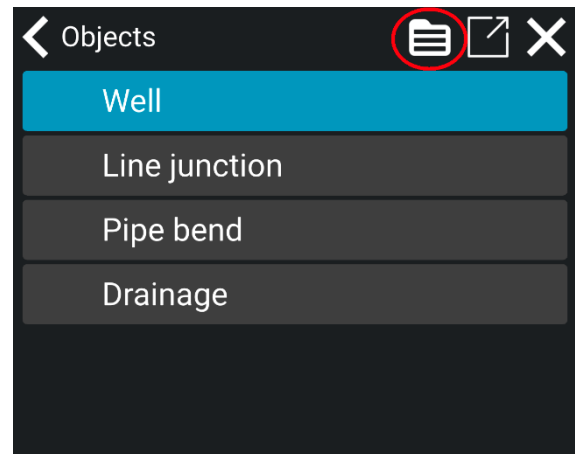
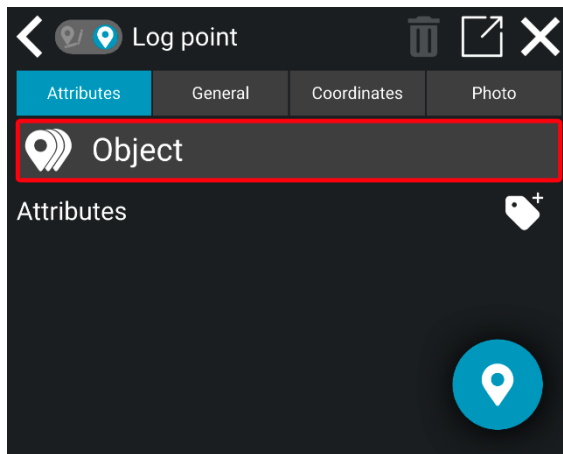

2) Choose the object group that suits your task.

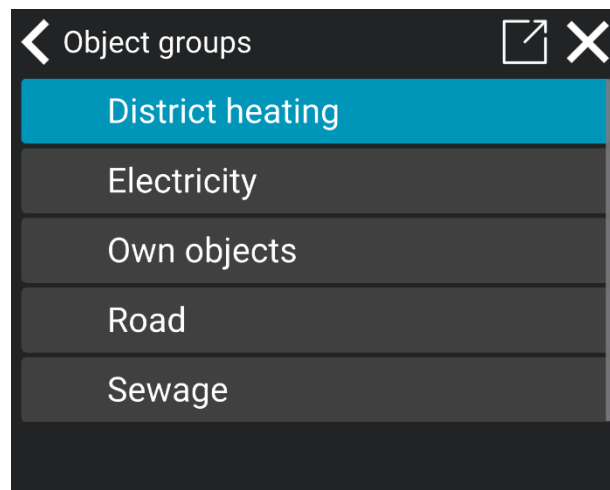

3) Select the relevant object from the list.

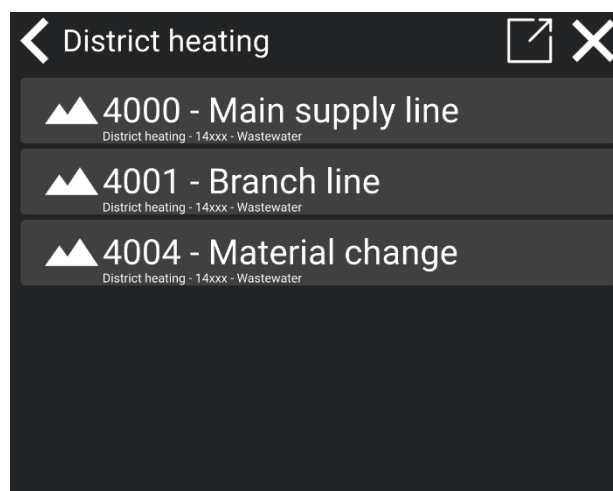

- 4) Once the object is selected, tap the **Log point** icon in the bottom right corner to log a point.

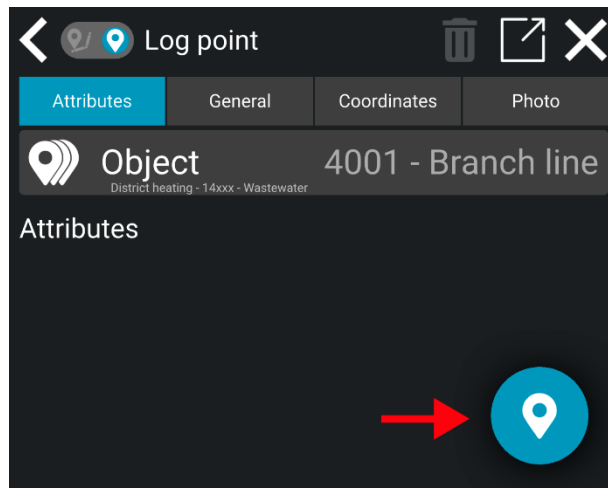

- 5) A notification will confirm the point has been logged, including the point number and object details.

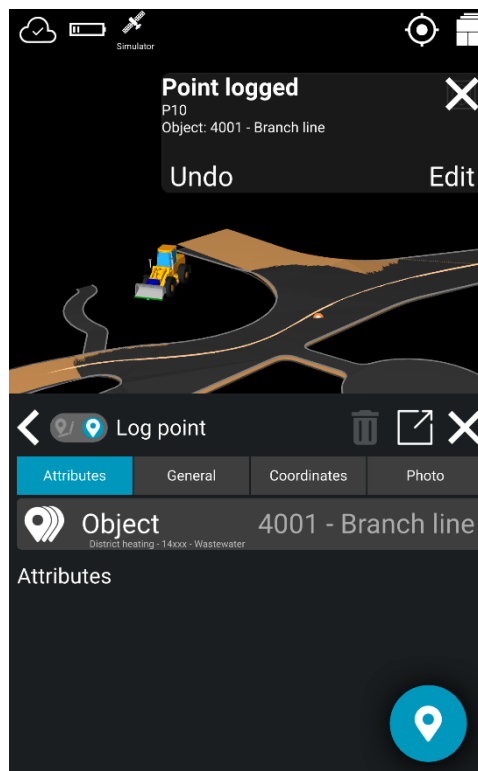

You can press **'undo'** if you regret your last logging. The confirmation pop-up will disappear after approximately 10 seconds.

Note! The last used object will remain active until it is changed.

7.2. Log Line

Log Line is an as-built functionality used to document how points are connected. Log Line can be used to document line breaks where there are changes in slope, direction, or if the project requires it, to document every line junction.

How to log a line:

- 1) Press and hold the **Log line icon** at the bottom of the screen for three seconds

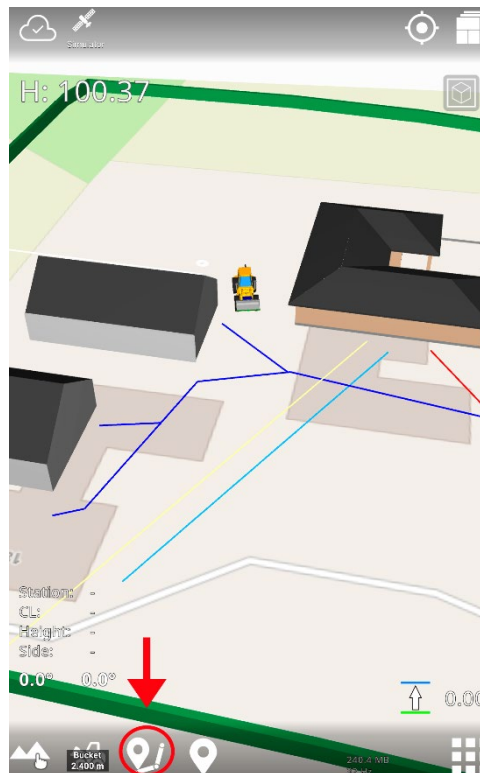

- 2) Choose the object that matches your task.

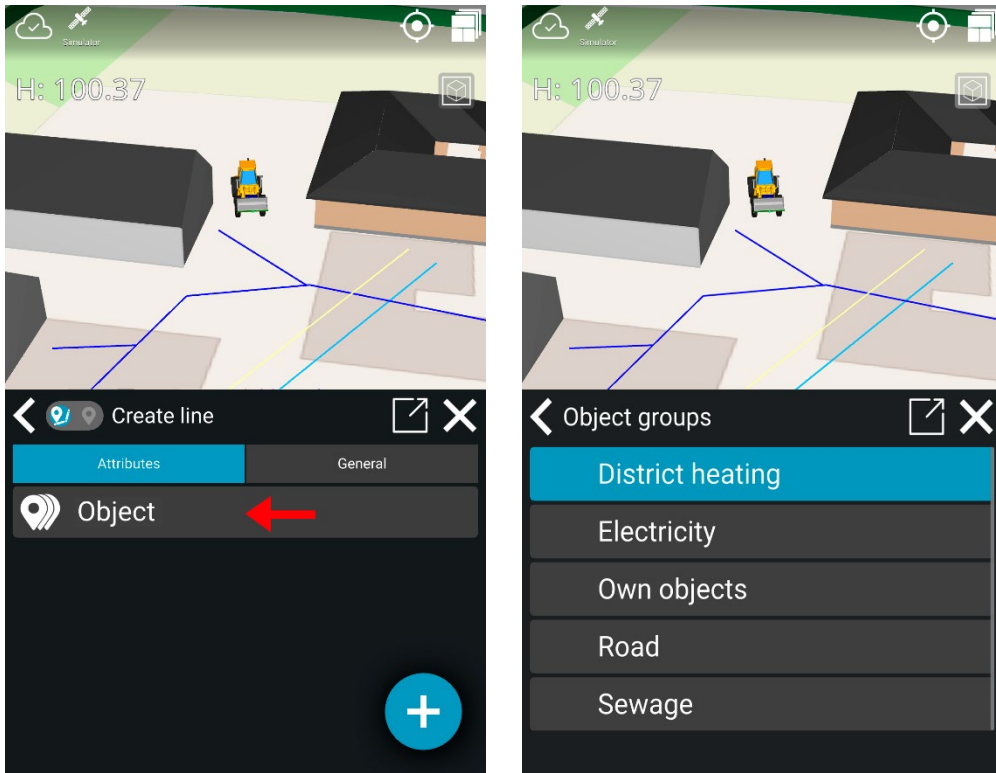

3) You can start logging a new line in one of two ways:

a. **Option 1:** By clicking the '+' icon located in the bottom right corner.

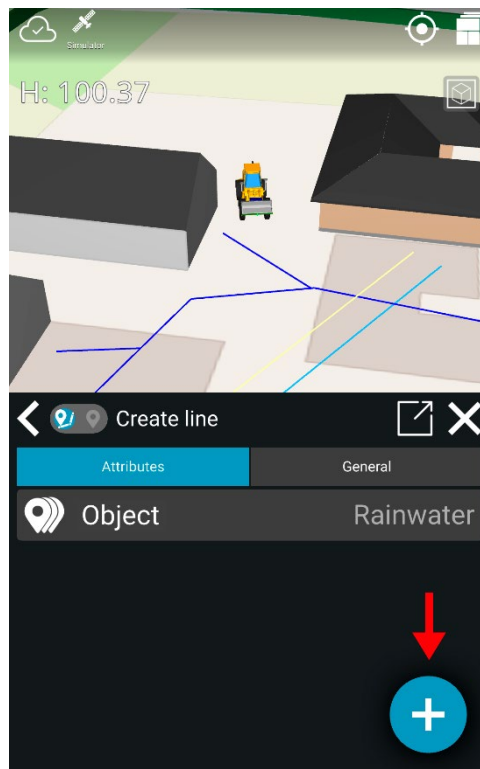

b. **Option 2:** Close the menu and then click on the log **line icon** on the work screen.

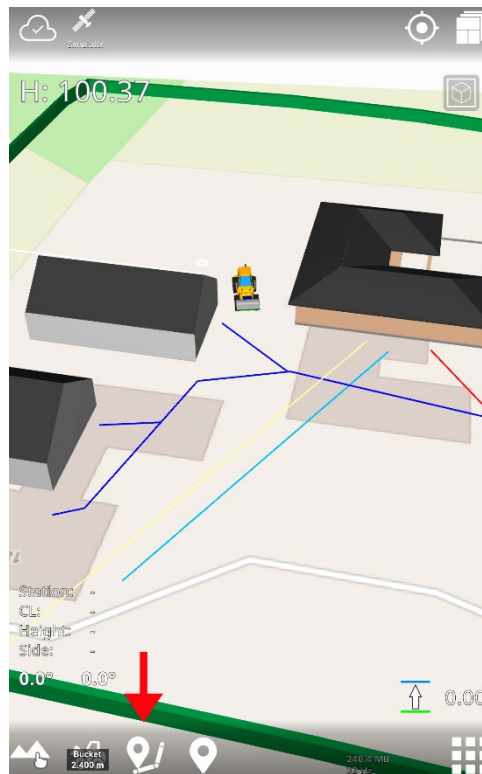

You can add line points by tapping the icon (see picture above).

4) To stop this line, press the **cancel log line** button at the top of the work screen. 

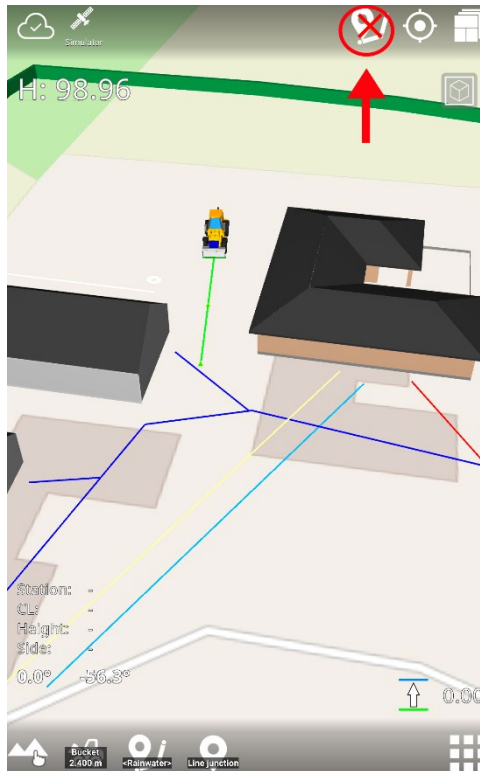

7.2.1. Log a new line from an existing line

It is possible to log a new line from an existing line. For example, you can easily log a line junction for a sewage project by logging a new line from an existing line.

How to:

- 1) Click on the line on the work screen, or go to *Project > References*, and activate the line by clicking on its name.

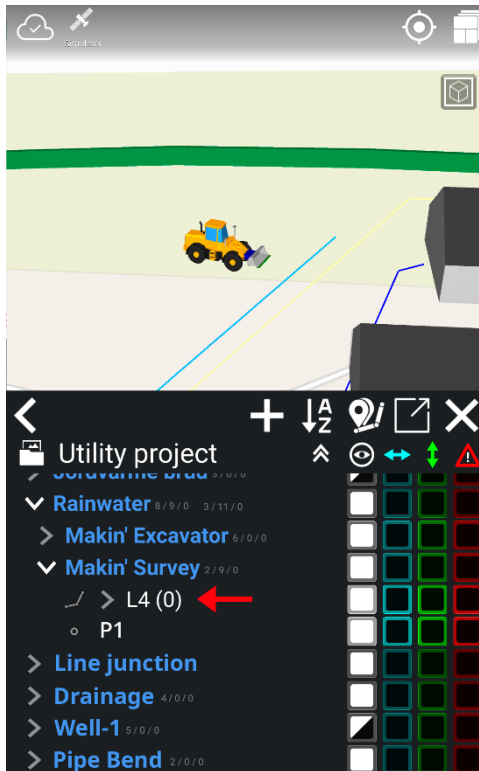

2) Click the gray arrow to expand the line and view the line points in the **Reference dialog**.

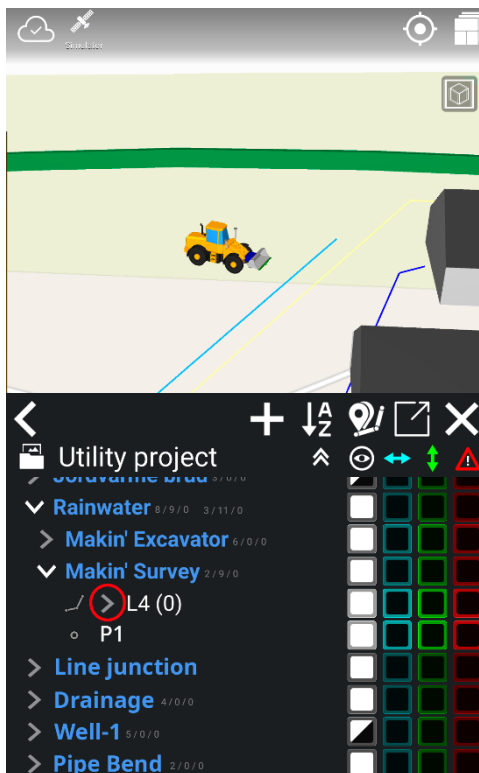

- 3) Choose the line point from where you want to start the new line and activate the line point by clicking on it.
- 4) Click on the 'Log line' icon.

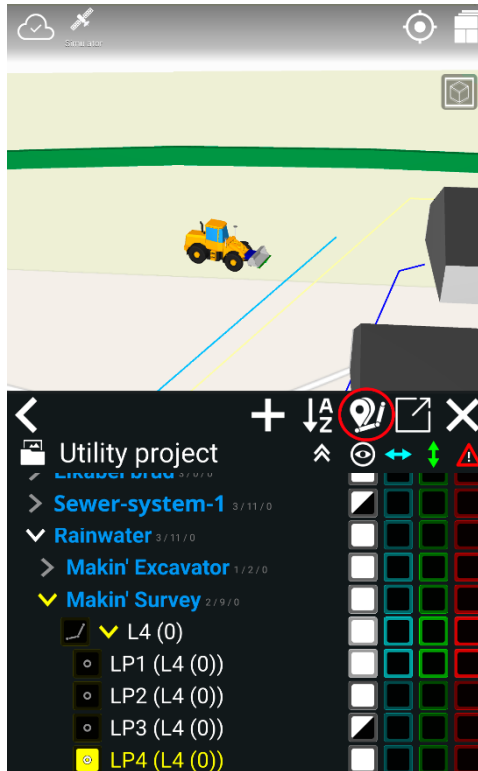

- 5) You can now log a new line from an existing line.

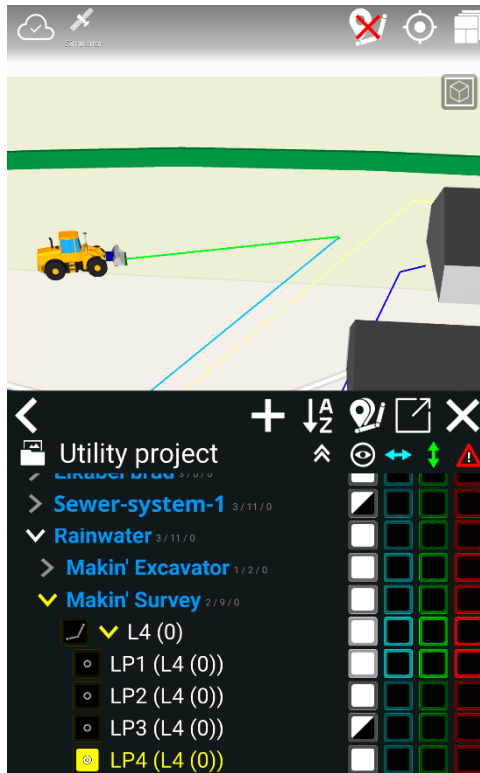

7.3. Swift between logging points and lines

You can log lines and points at the same time. You can, for example, log a line by short-pressing the **log line icon** at the bottom of your work screen, and when you want to log a point, you can simply short-press the **log point icon**. Even if you move the machine after logging a point, it remains in log line mode, allowing you to log points at the same time.

Line logging-mode



Logging a point while logging a line:



7.4. Own objects

You can create your own objects this way:

- 1) Select **Logging** in the menu.
- 2) Select 'Object'.

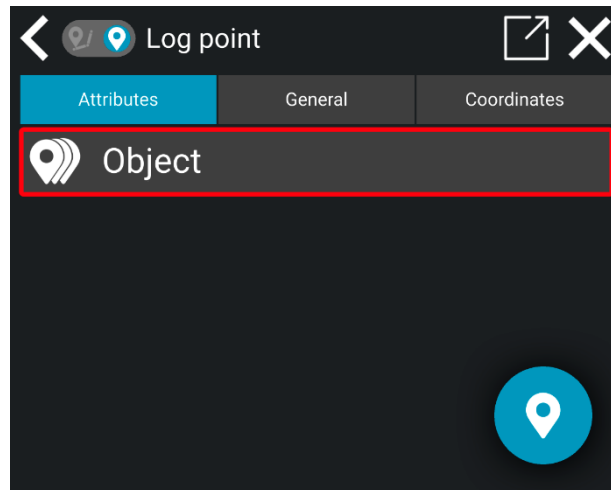

- 3) Tap the folder icon.

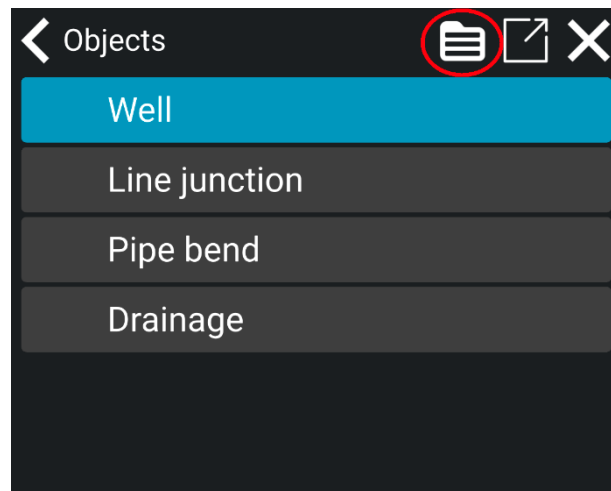

- 4) In 'Object group', select '**Own objects**'.

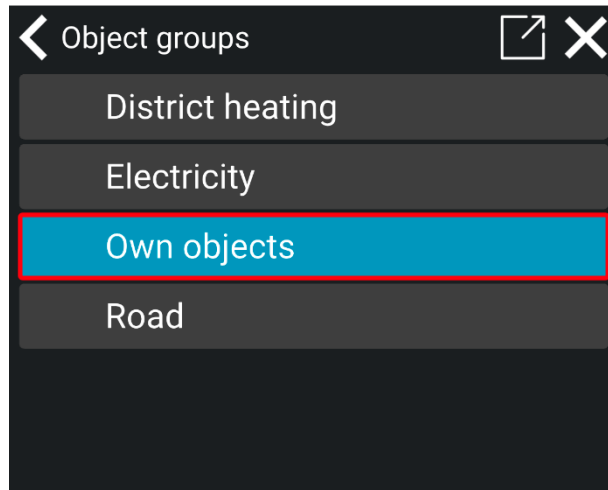

5) Tap '+'.

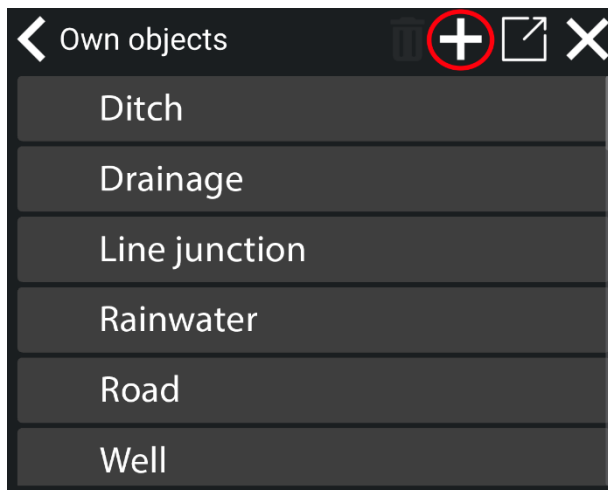

6) Name your object.

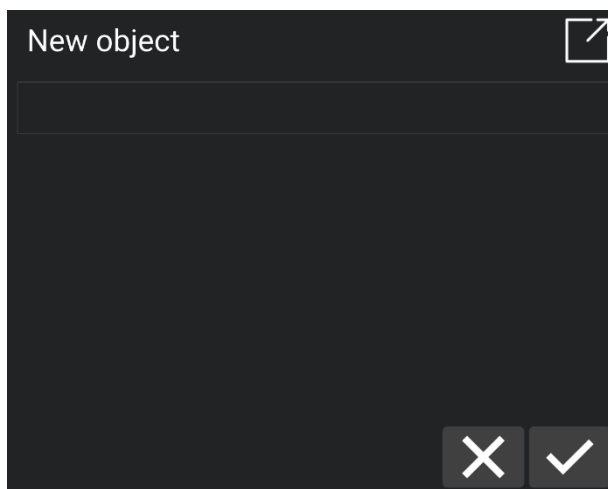

7) Tap the check mark to save.

The new object is now stored under 'Own objects' and is automatically selected as the default object for point logging.

7.5. Log offset

You can log an offset for both point and line point heights:

1) Go to *Coordinates > Log offset*

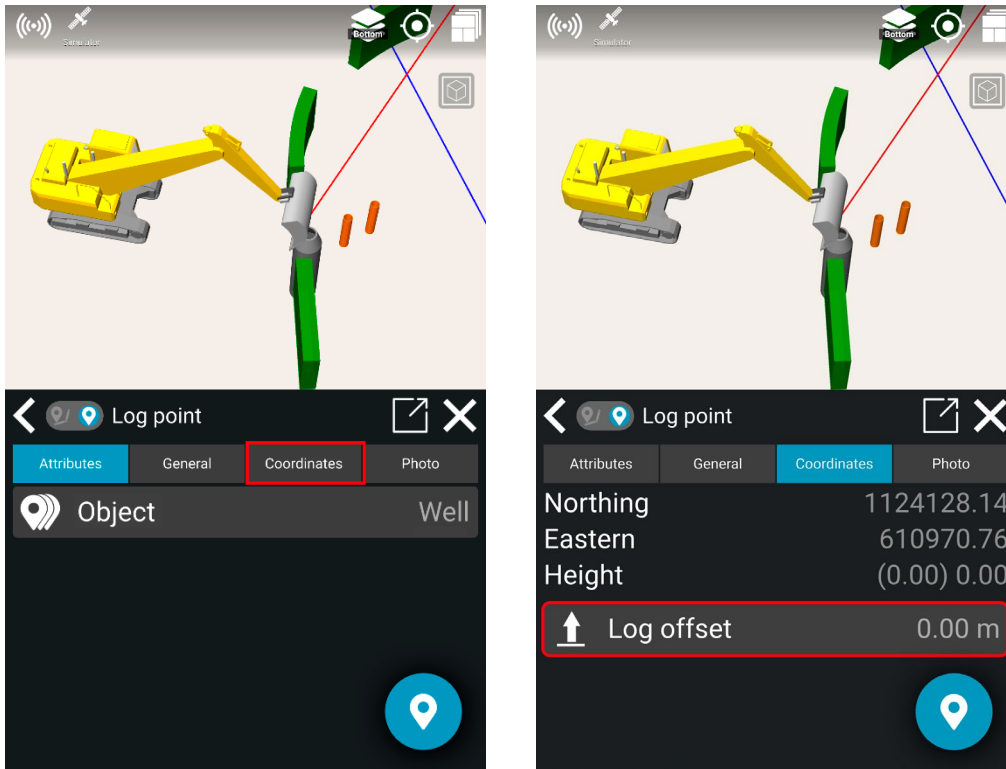

2) Enter the measurement for the offset.

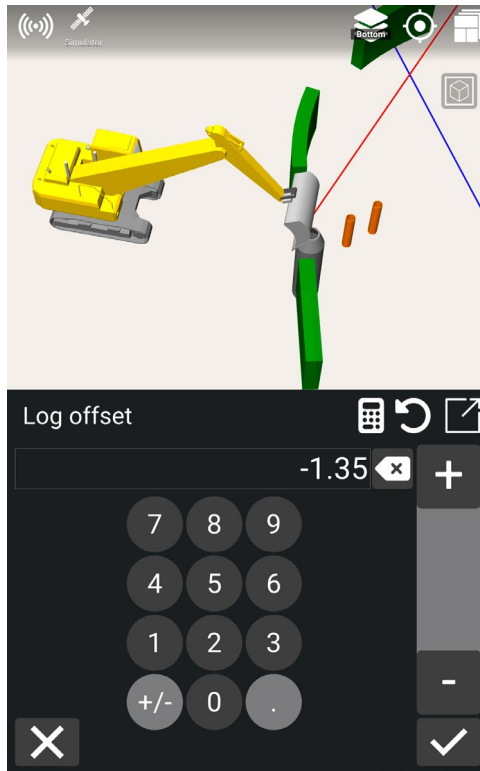

3) Click on the check mark.

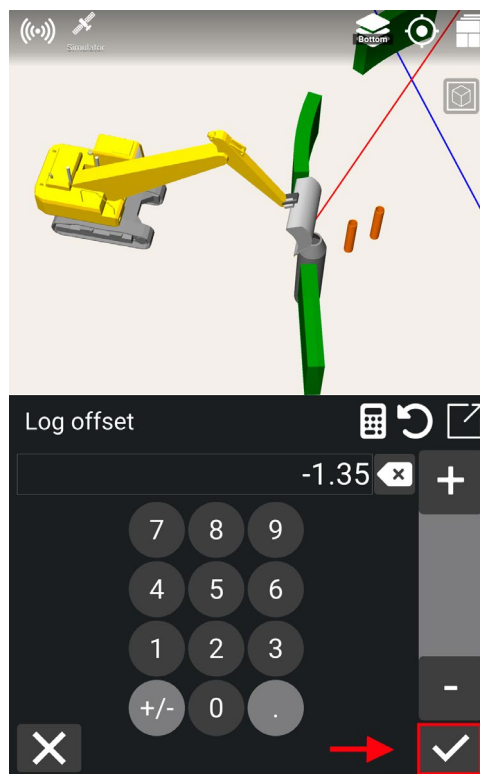

4) The result will show two numbers for the height, like this: **(0.00) -1.35**. The number in the parenthesis is the logged point's height, and the number after the parenthesis is the calculated height after applying the offset.

5) Click on the **log point icon** in the bottom right corner.

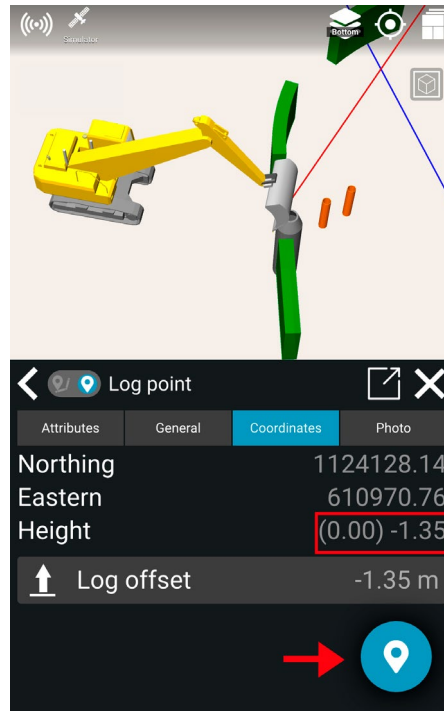

6) You have logged an offset for the point or line point:

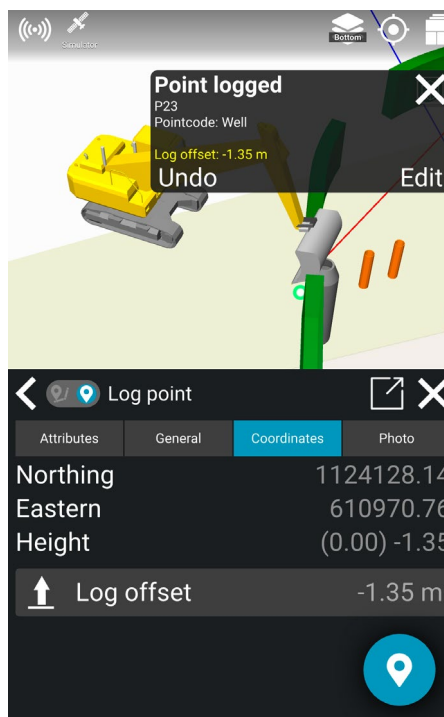

7.5.1. Edit a log offset

To edit a log offset for a point or a line point:

- 1) Go to *Project > References*
- 2) Click on the point or line point name.

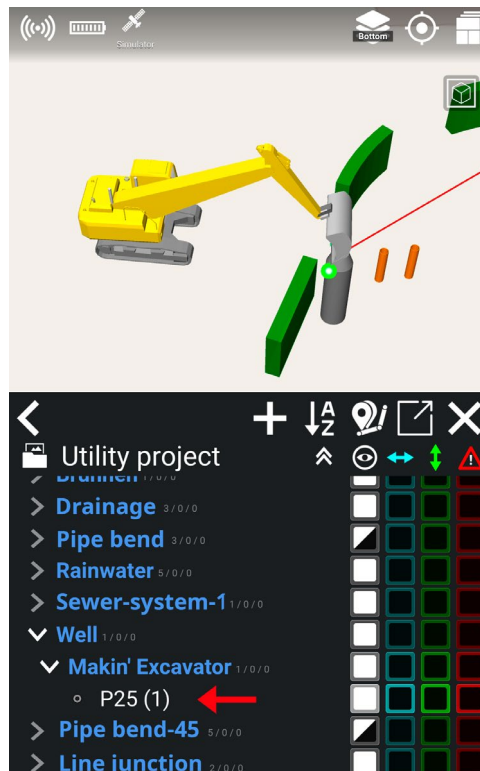

- 3) Click on the **pen tool** to edit.

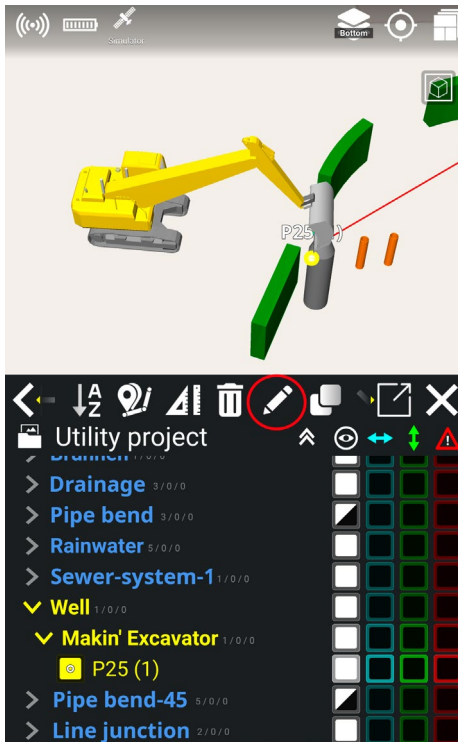

4) Go to 'Coordinates'.

5) Click 'Log offset'.

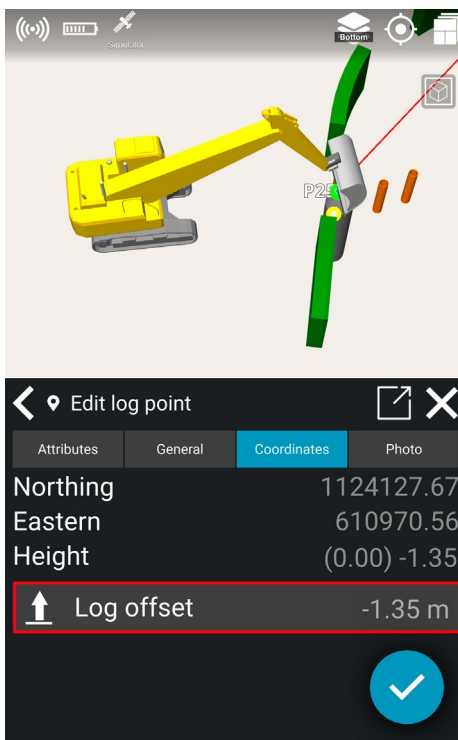

- 6) Set the offset and click on the check mark.
- 7) Click on the check mark in the bottom right corner.

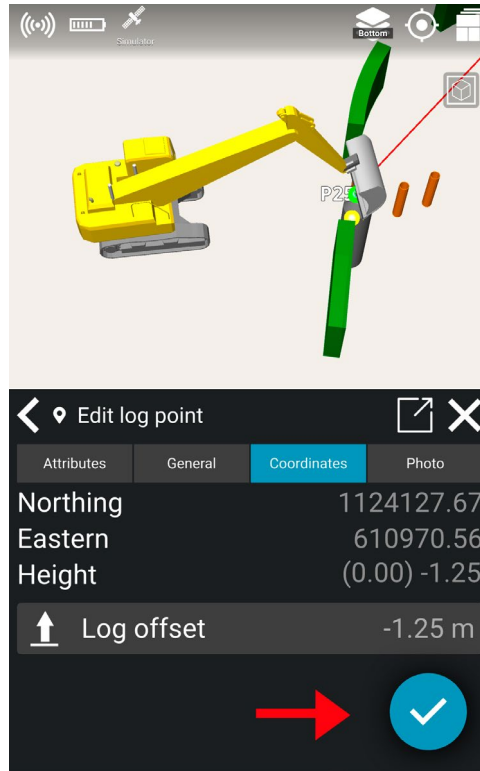

- 8) The offset is now edited.

7.6. Object information and attributes

When a point is logged, several different pieces of information are logged together with the object and coordinates. Below, you can see a list of information with an explanation of the different values.

<p>Point name: A unique name used to identify individual points</p>	<p>N: The measured points northern coordinate. This value is measured on the tool point</p>
--	--

E: The measured points' eastern coordinate. This value is measured on the tool point	H: The measured points elevation. This value is measured on the tool point
VRMS: Shows the vertical accuracy of the GNSS when the point was logged. Accuracy is defined on the GNSS antenna, not the tool point	HRMS: Shows the horizontal accuracy of the GNSS when the point was logged. Accuracy is defined on the GNSS antenna, not the tool point
Mount point: Shows which mount point was chosen for the connected NTRIP server	Project offset: If an application has a project offset entered to adjust tool point elevation to match the elevation of a known point on the construction site.
ExtSurf: Showing if the point measured is done on an extended surface value can be 0(no) or 1(Yes)	ToolHeight: Shows the height offset applied to the measured tool point, e.g. Pole height for Makin' Survey, or Tablet height for Makin' PerFormans
Time: The time where the point was logged logged in a YYYY-mm-dd HH:MM:ss format Example: 2022-02-15 09:43:34	SystemName: Shows the name of the system that logged the point. This system name matches the system name on the Cloud
PDOP: Dilution Of Precision, indicates how errors in measurement will affect the absolute position calculation. Dop can be calculated in different variants. (HDOP, VDOP, PDOP, TDOP, GDOP) The DOP value logged in the as-built data is the PDOP value. (Position dilution of precision) This can be considered as the 3D DOP. The value is relative and not related to a specific measurement unit.	Sats: Showing how many satellites were visible when the point was logged. The value is the sum of satellites, and not divided into specific satellite constellations (GPS, Glonass, Beidou, Galileo)
LogOffset: Delta height. Shows if the operator has added an offset to the logged point. Often used if it is impossible to log the exact position due to limited space. E.g., logging the inlet in a manhole. Then the operator can log a point on the top of the manhole, measure the distance from the measured point to the inlet, and enter this as a delta height.measured. Value shows accuracy in meters	SiderefFile: Side reference file. Shows the name of the file used as active side reference when point was logged
App: Shows which system has logged this specific point.	SiderefName: Side reference name. Shows the name of the specific reference inside the reference file, used as an active side reference when a point was logged.
HeightOffset: If the operator has entered an offset, the value is documented in this field. This offset will have a direct effect on the Href value.	Sidedist: Shows the horizontal distance from the tool point to the side reference when the point was logged.

<p>POI: This is set if the operator has marked a point as a Point Of Interest. The value can be 0 (no) or 1 (yes).</p>	<p>HeightrefFile: Height reference file. Shows the name of the file used as the active height reference when the point was logged.</p>
<p>ToolPoint: Shows which tool point was used to log the point. Only relevant for Excavators that can switch and log with Left, Center and Right tool point on the bucket.</p>	<p>HeightrefName: Height reference name. Shows the name of the specific reference inside the reference file, used as the active height reference when the point was logged.</p>
<p>Height: Shows the vertical distance from the tool point to the height reference when the point was logged.</p>	<p>Comment: If the operator has written a comment for the point, it will be shown here.</p>

7.7. Sort as-built data

Inside the reference menu, it is possible to enable sorting of the project's as-built data. Press the AZ button to open the sorting dialog.



In this dialog, you can choose which criteria you want to sort by. Press the button to activate or deactivate the criteria. You can also change the order you want to sort by. This is done by pressing and holding on a criterion and then moving it up or down the list.

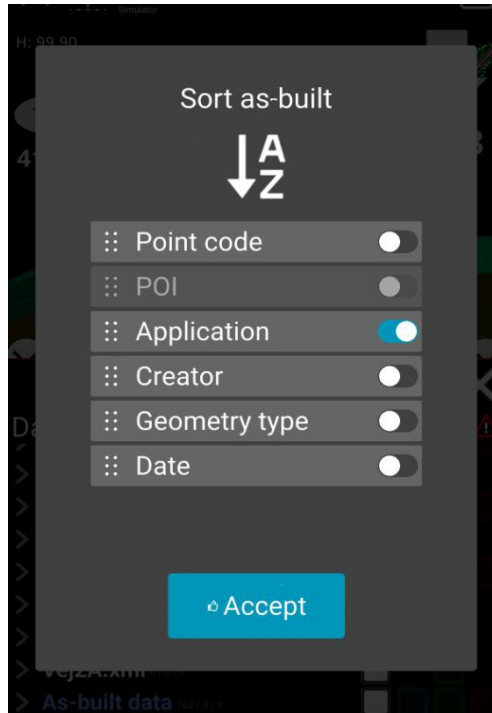

8. GNSS

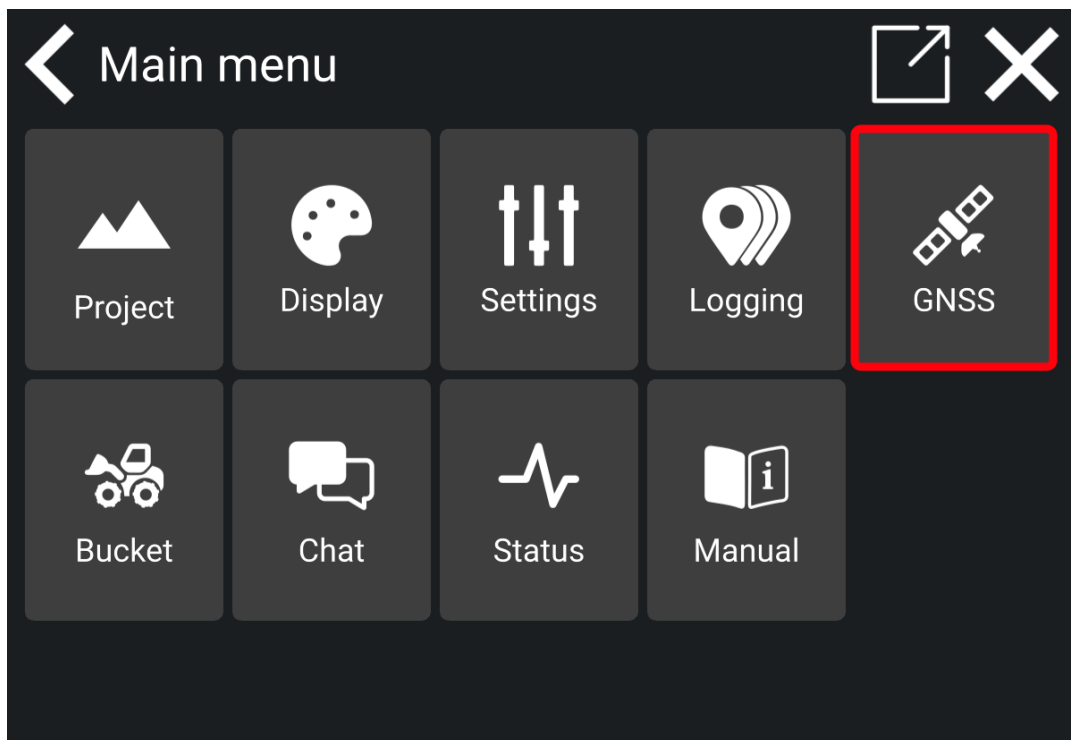

8.1. Correction source

In the 'GNSS' menu, you can choose whether you want to run with the GPS receiver towards **NTRIP** (CPOS, Smartnet, TopNet) or **UHF** (radio) towards a local base station. If you choose UHF, you must select the frequency and ID that allow Makin' 3D to communicate with the base you want.

How to choose and create a correction source:

- 1) Go to *GNSS > Correction source*

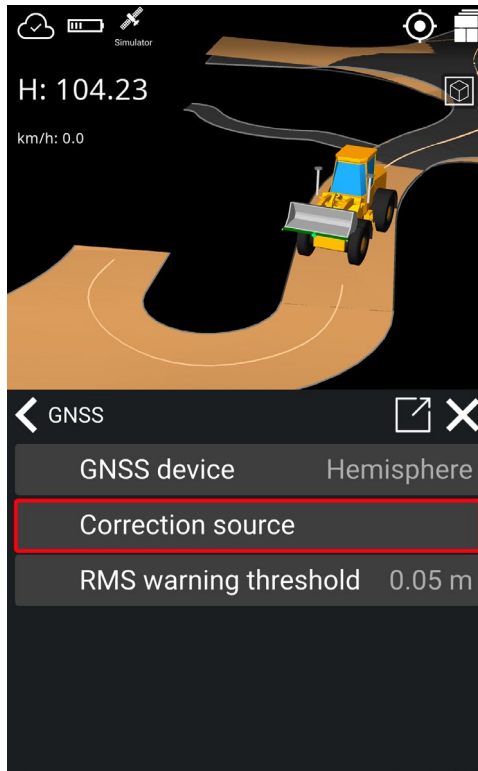

- 2) In the correction source dialog, you can activate and deactivate NTRIP and UHF profiles. You can also create or edit a correction profile.

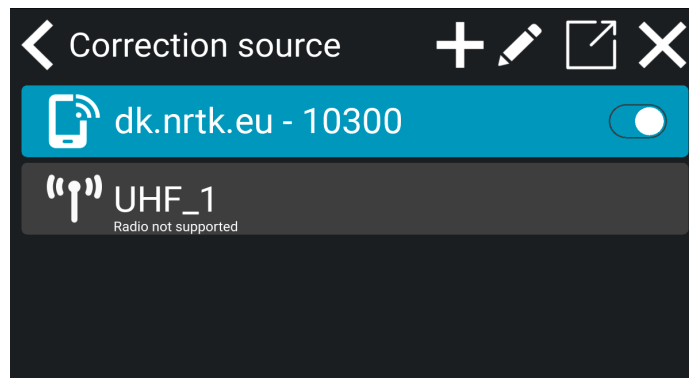

- 3) To create a correction profile, tap on the **+** symbol. Edit a correction profile by tapping on the **pen tool**.

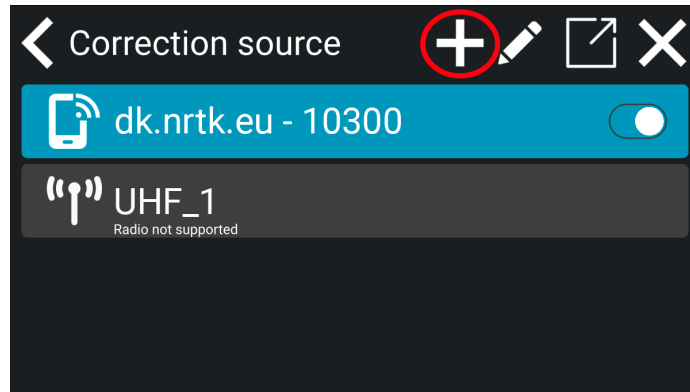

- 4) When tapping on the '+' symbol you can choose between creating a NTRIP or UHF profile. See the paragraphs below for more information about UHF and NTRIP.

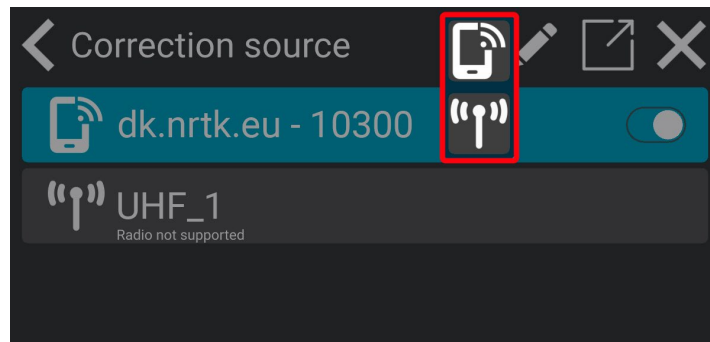

8.1.1. Radio (UHF)

Under '**Correction source**' you see the current type of correction source being used.

- Choose 'UHF' if you use a radio to connect to the correction signal.

How to create a new UHF profile:

- 1) You can create a new UHF profile by tapping on '+' symbol and then the **UHF icon**.

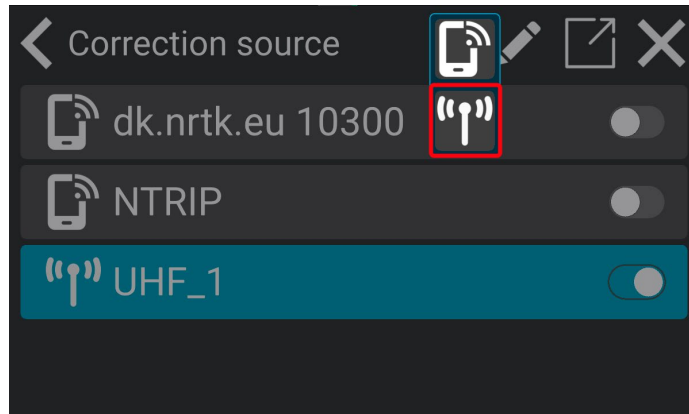

2) To set up the UHF profile, the following details must be entered:

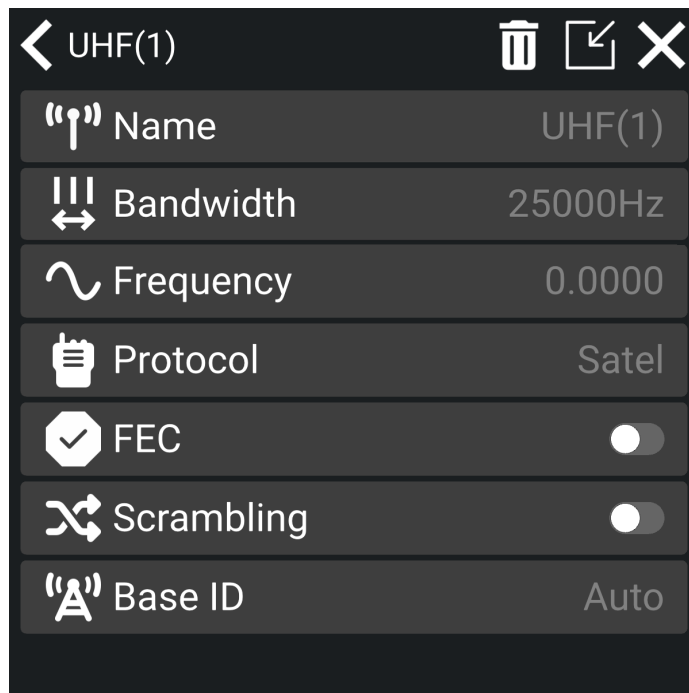

- **Name:** Name the UHF correction profile.
- **Bandwidth:** Select either 25000Hz or 12500Hz.
- **Frequency:** Tap 'Frequency' to set the frequency of the base station.
- **Protocol:** Choose the protocol you want to use.

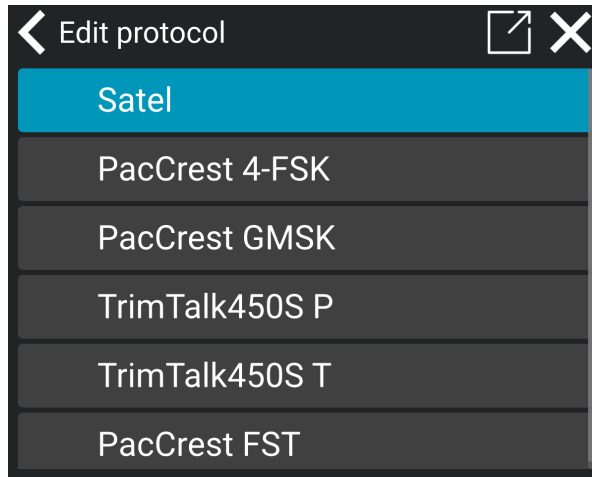

- **FEC:** Tap the button to activate or deactivate the FEC.
- **Scrambling:** Tap the button to activate or deactivate the scrambling.
- **Base ID:** Tap 'Base ID' and choose 'Auto' to automatically jump between base stations with the same frequency or choose an ID of a specific base station to lock on to it by tapping on 'Custom'.

Please note, that if you use the 'Auto' option, you might experience corrections from two bases, which is not optimal.

- 1) Choose between 'Auto' or 'Custom' to set the **Base ID**.

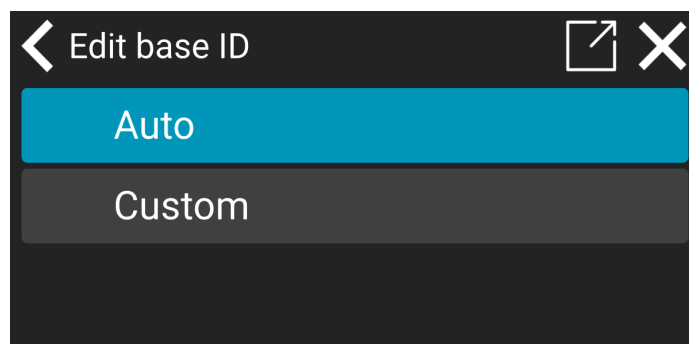

- 2) Tap on '**Custom**' to choose an ID of a specific base station.

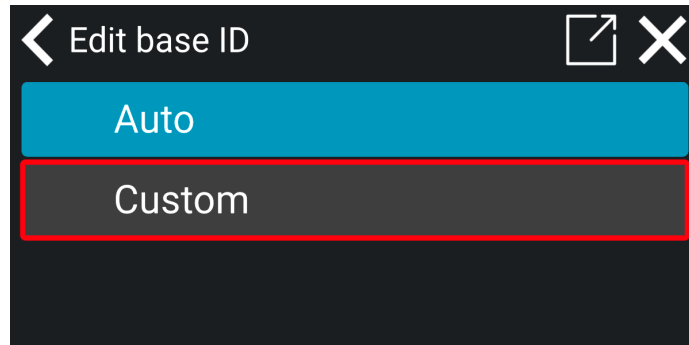

- 3) Set the ID of the specific base station you want to lock on to. Tap on the check mark to save.

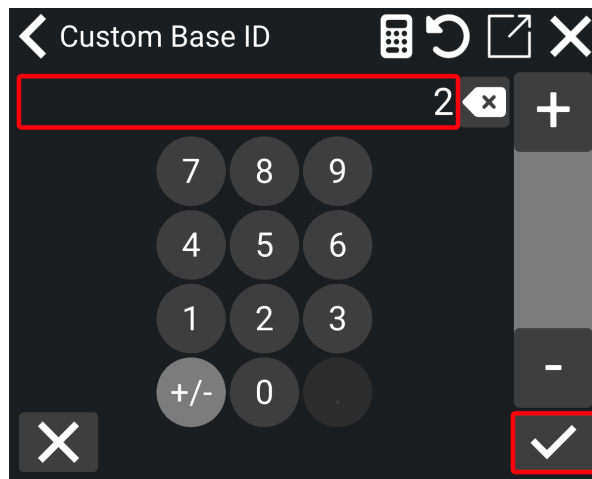

When you have created a UHF correction profile, you can activate the correction source you want to use. The current correction source will automatically deactivate.

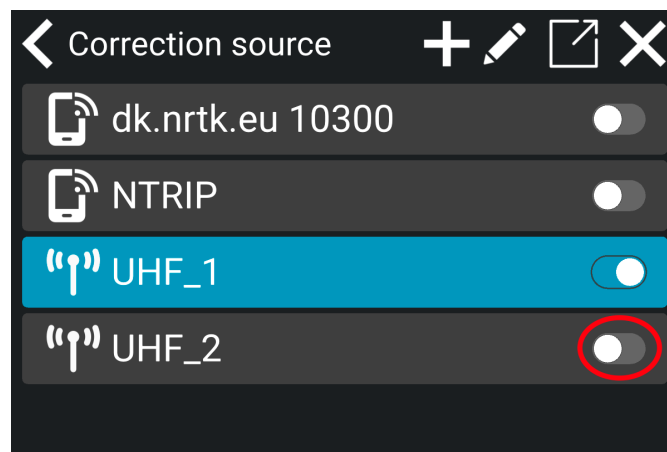

8.1.2. NTRIP

Makin can use corrections from several NTRIP providers. Depending on the installed GNSS receiver, the information must be entered by the Makin' supporter or installer in the Makin' application's GNSS menu. Makin needs some NTRIP server details to be able to connect to the server and receive useful corrections. These details will be delivered from the selected NTRIP provider when subscribing to an account.

- 1) You can create a new NTRIP profile by tapping on '+' symbol and then the **NTRIP icon**.

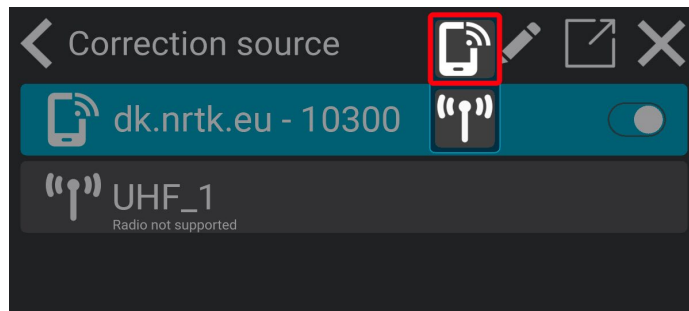

- 2) To connect to the NTRIP network and receive corrections, the following details must be entered:

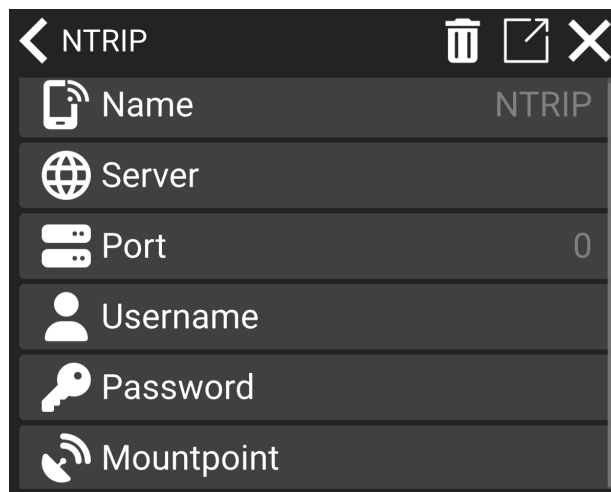

- **NTRIP name:** Name the NTRIP correction profile.
- **NTRIP server:** The web address where the server can be accessed.

- **NTRIP port:** This is usually a 4-digit number from where Makin must receive the corrections.
- **NTRIP username:** Every Ntrip account on the server has a unique username that Makin needs to log in to the server.
- **NTRIP password:** Every Ntrip account on the server has a unique password that Makin needs to log in to the server.
- **NTRIP mountpoint:** This mountpoint defines which corrections and from which GNSS satellites Makin can calculate an accurate position.

Please note that the **mountpoint** is custom. You need to fill in the details for the mountpoint.

- 1) Tap on '**Mountpoint**'.

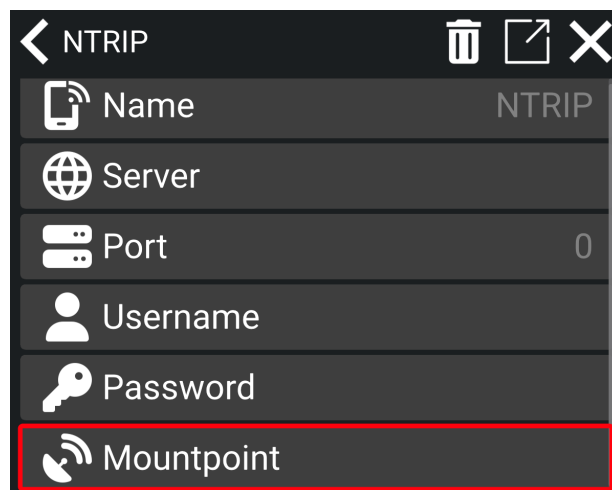

- 2) Tap on '**Custom**'.

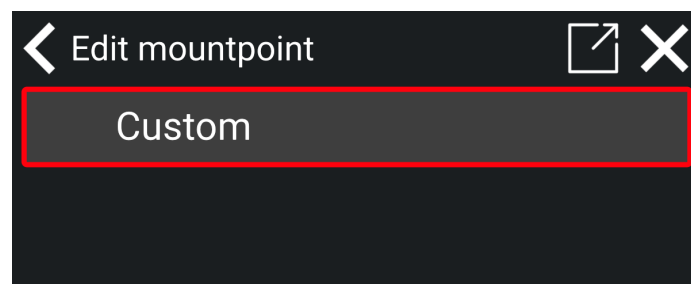

3) Enter the mountpoint name. Tap on the check mark to save.

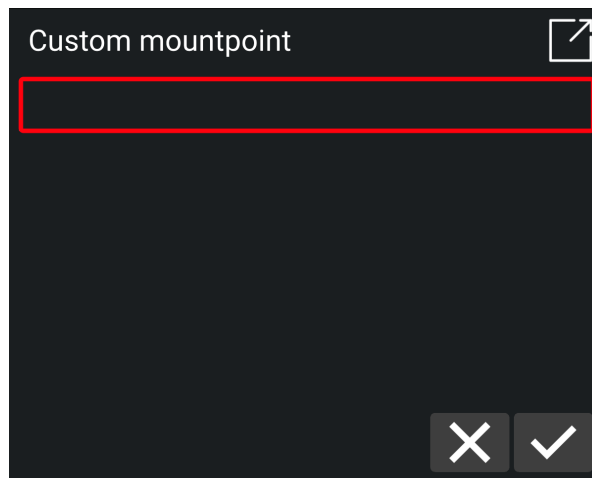

When you have created a NTRIP correction profile, you can activate the correction source you want to use. The current correction source will automatically deactivate.

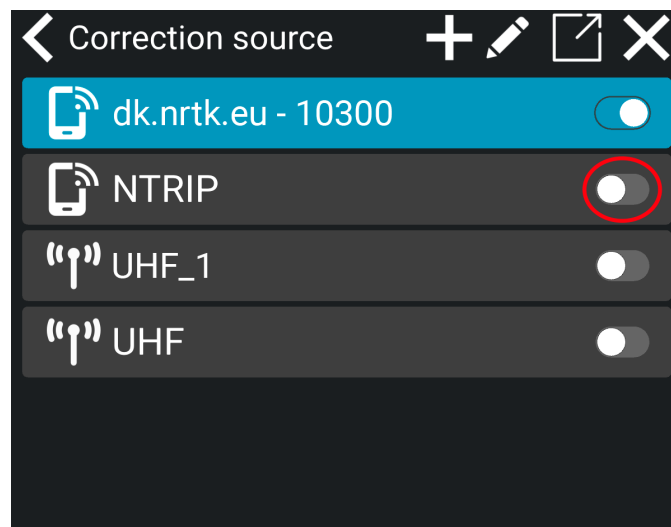

9. Bucket

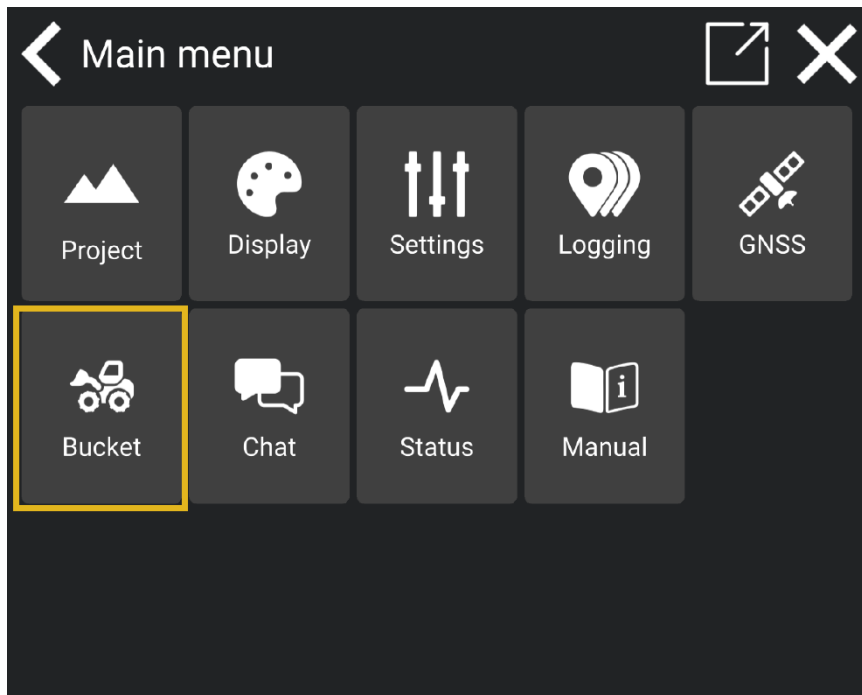

There is a shortcut to this menu from the quick keys in the bottom left corner of the work screen

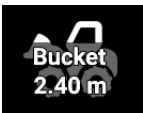

You can create a new bucket or see all the buckets saved on the tablet. Tap the bucket you want to use, and always ensure that the calibration is correct before starting work.

Create a new bucket:

Tap the '+' button to create a new bucket.

Edit an existing bucket:

Select an existing bucket and tap on the **pen tool** to edit the bucket's name and measurements.

For calibration, see Chapter 12: *Calibration*.

To check your calibration, see Chapter 12.3: *Check the calibration of your wheel loader*.

9.1. Cutting Edge

You can select the position of the active tool point to be at either the front or back of the bucket. This allows you to place the cutting edge where it best suits your task.

- 1) Go to *Main menu > Bucket*.
- 2) Tap on '**Cutting edge**'.

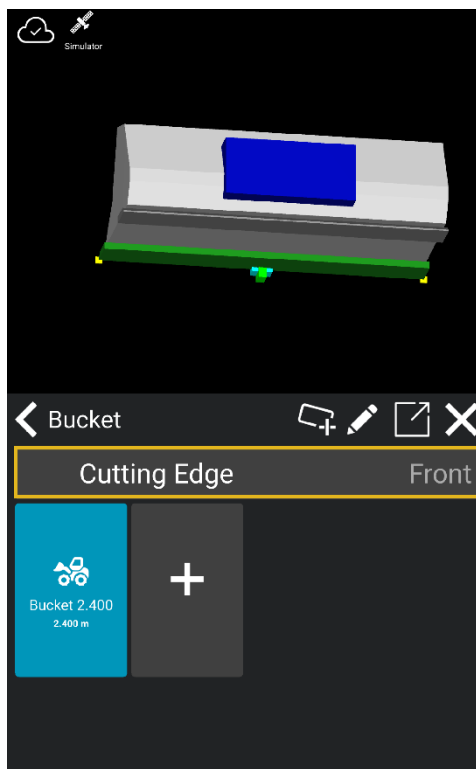

- 3) Choose between 'Front' or 'Back'.

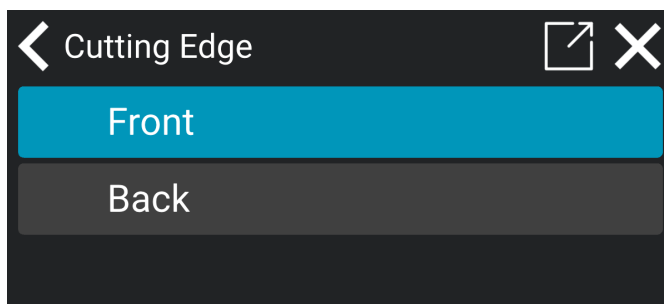

9.2. Auto-Corner

Du kan manuelt vælge, hvilket hjørne af skovlen du vil bruge som værktøjspunkt, men hvis din maskine har tilt, kan du alternativt bruge Auto-Corner-funktionen. Når Auto-Corner-funktionen er aktiveret, vælger systemet automatisk det laveste punkt på skovlen som værktøjspunkt.

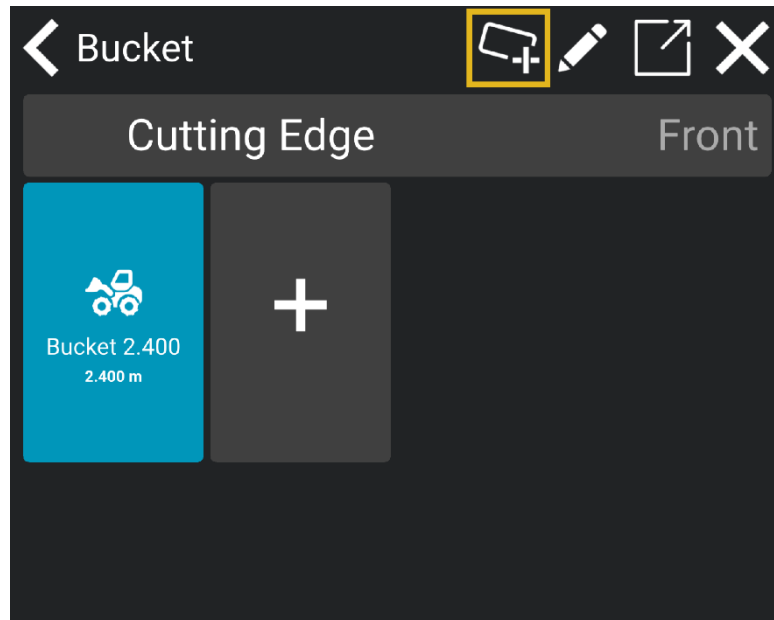

Når funktionen er aktiveret, vises Auto-Corner-ikonet i topbjælken, og det angiver løbende, hvilken side af skovlen du måler fra, afhængigt af hvordan skovlen er tiltet.

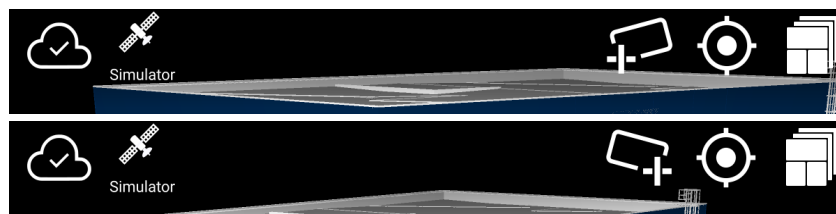

10. Chat

The chat feature helps you communicate with your colleagues about the project you are working on.

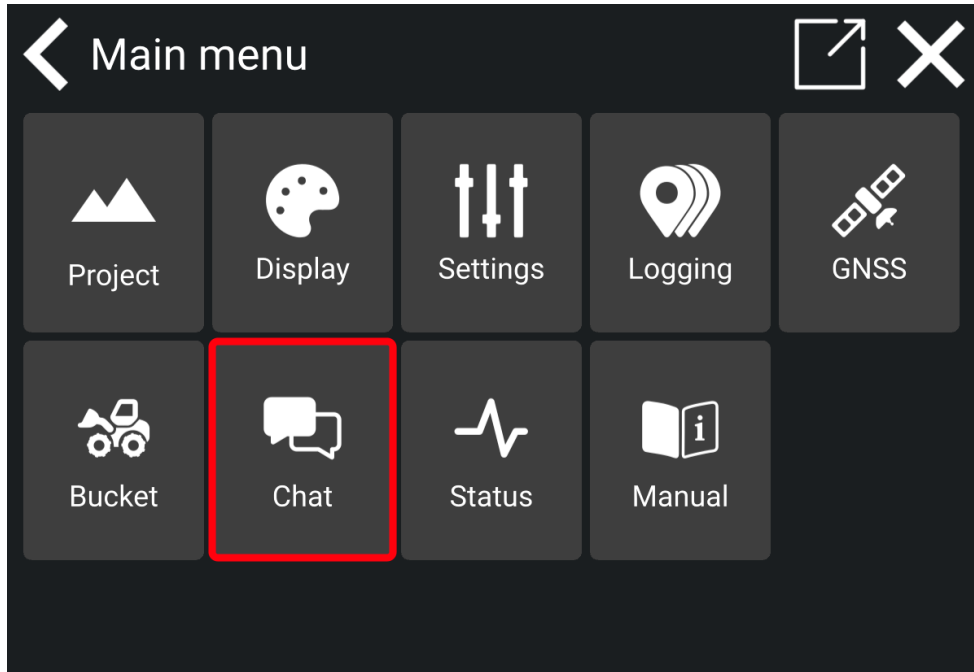

- You will see all office personnel and coworkers from your company or project. This depends on the structure created by your management.
- Tap a contact from the list to begin messaging.

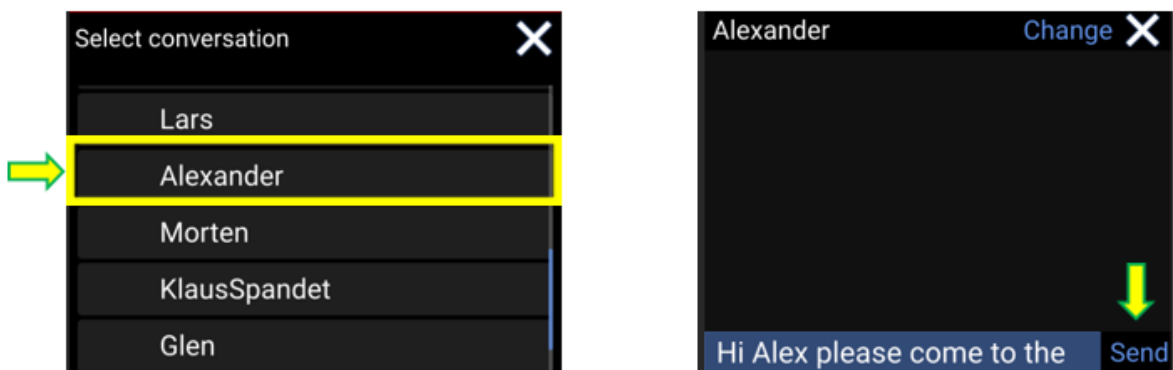

- Write a message and tap '**Send**'.

11. Status

This is where you will find various details about the system information.

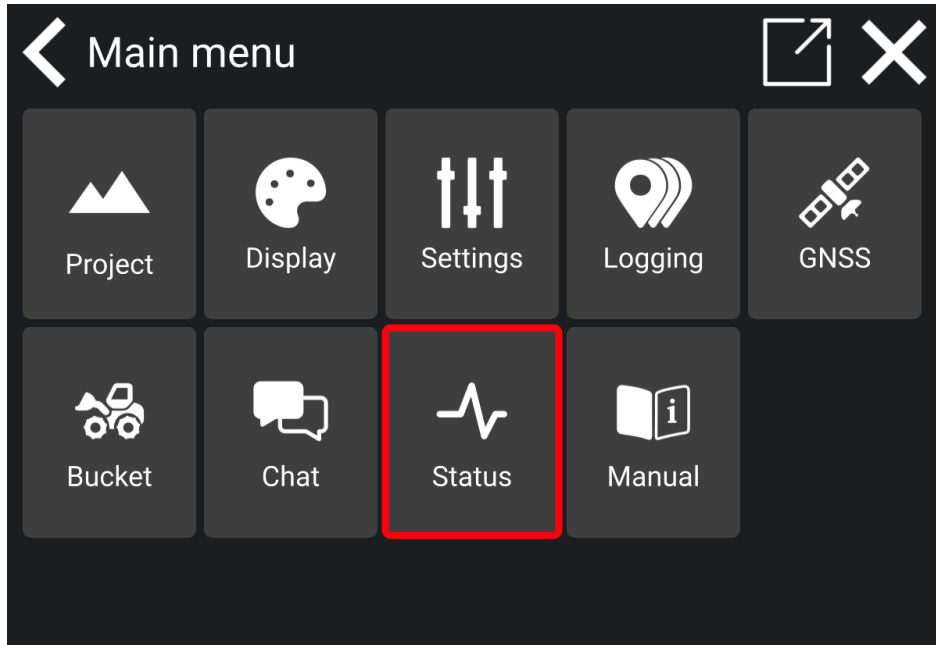

- Tap 'GNSS' to see the connection status and your location.
- Tap 'Sensors' to see detailed sensor information.
- 'Version' is the current Makin' 3D software version of the Android app running on your tablet.
- 'IB-1 version' is the firmware version of the interface box connecting all the sensors to the system.

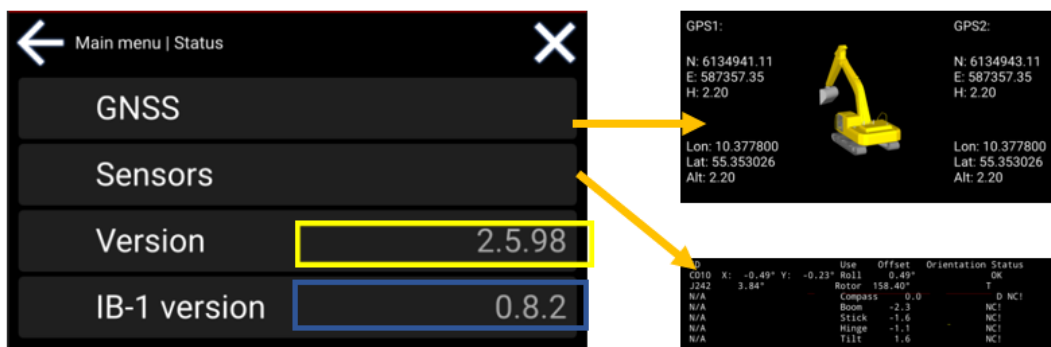

- **System info:** You can find all relevant information about your system by selecting 'System info'. Information such as System name, System number, System owner, and the associated licenses are shown here. When changes are made to the system, they will be shown under System info.

12. Calibration

12.1. Bucket calibration

Always place your machine on the most stable surface possible and read through the full chapter before starting.

12.1.1. Tools required

- Spirit level



- Tape measure



12.2. Bucket calibration menu

Go to the bucket menu from the main menu. See Chapter 9: *Bucket*, for further details.

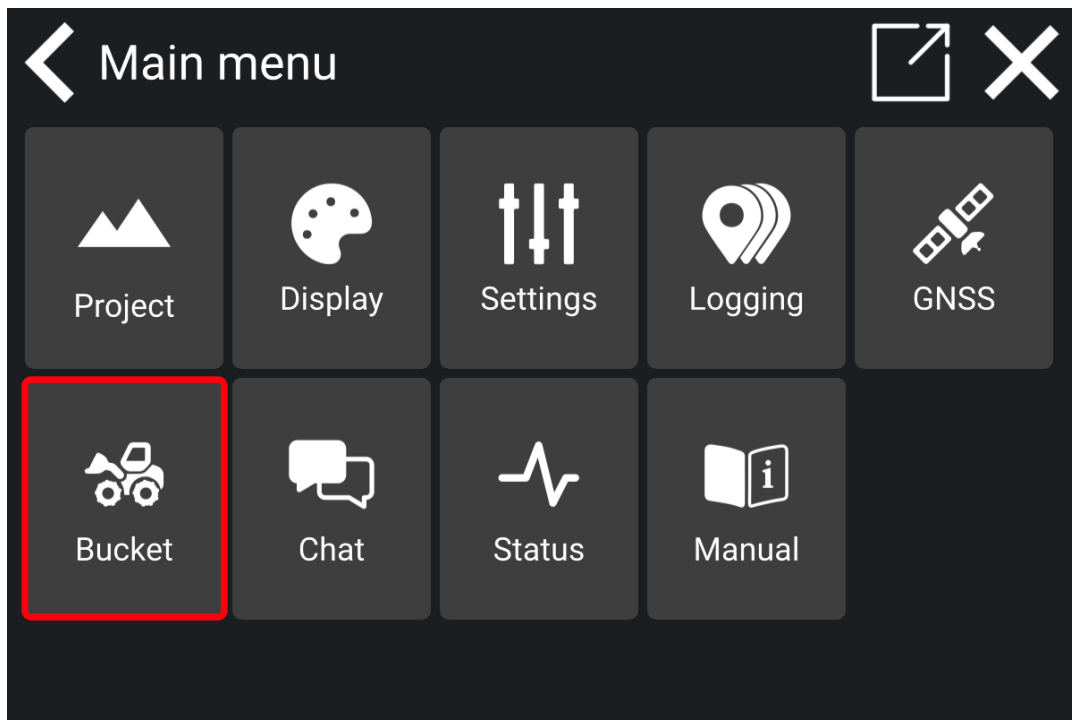

Add a new bucket

If you want to add a new bucket, tap the '+' symbol.

Calibrate a bucket

- 1) Tap the bucket you want to calibrate.

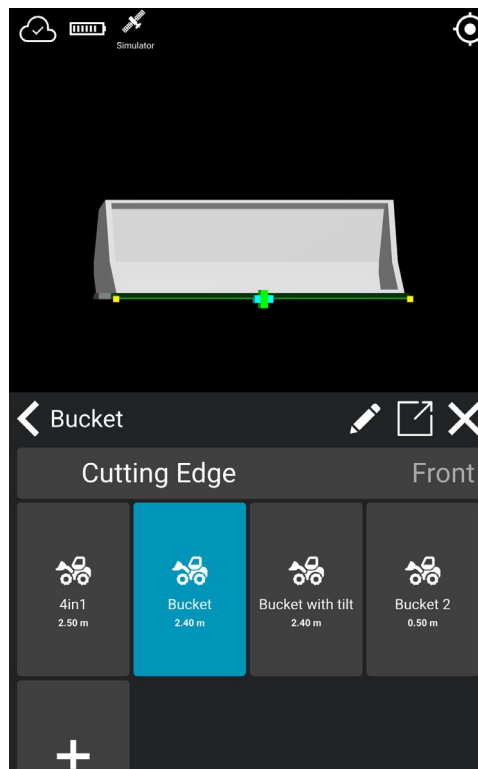

- 2) Tap the **pen symbol** to begin calibrating.

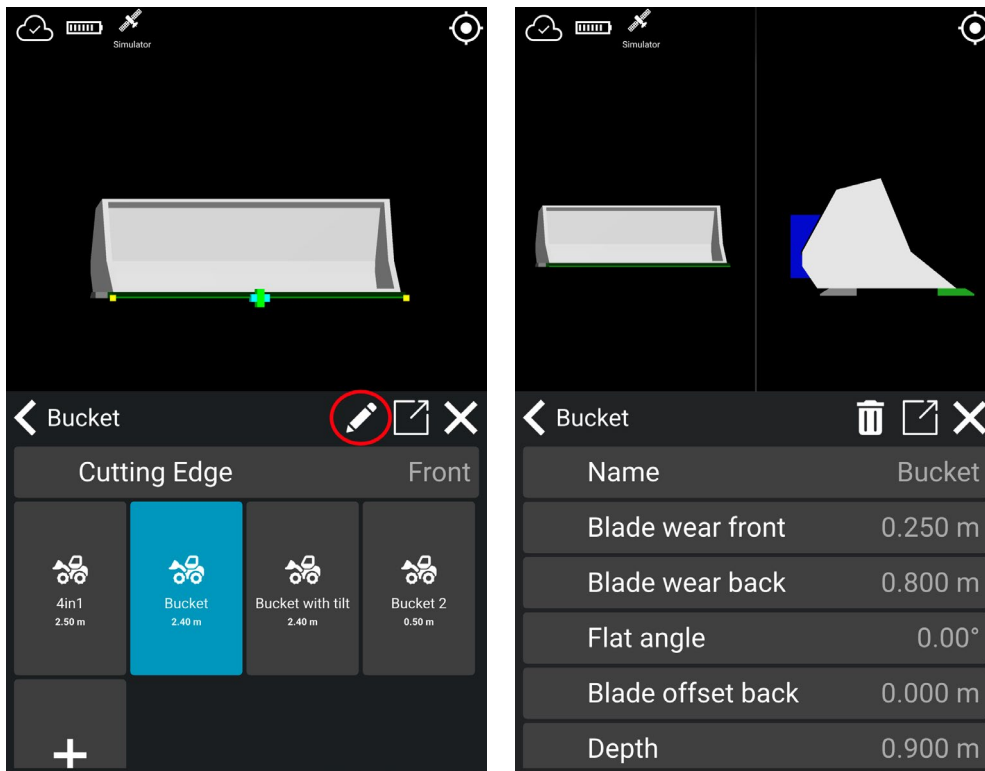

12.2.1. Bucket name

In the bucket calibration, tap **Name** to edit the name of the bucket. Type the name and tap the check mark to save.

12.2.2. Blade wear front

In the bucket calibration, tap **'Blade wear front'** to enter the length of the front blade. When the blade wears out, enter the new measurement for accurate calibration.

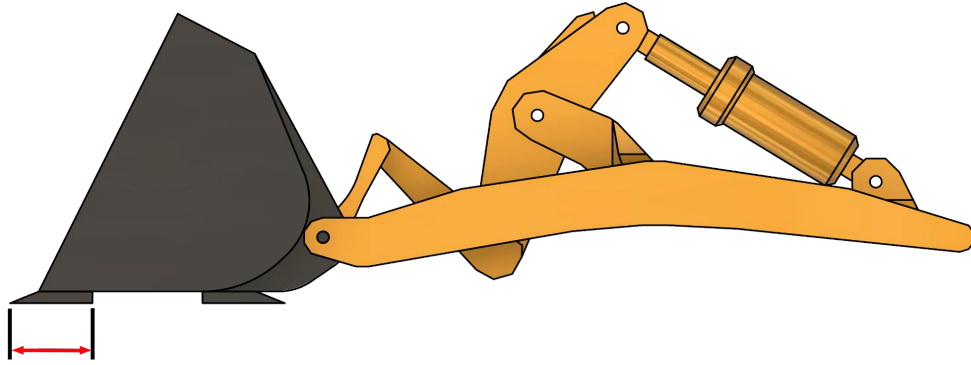

12.2.3. Blade wear back

Tap **'Blade wear back'** to enter the length of the back blade. Measure the distance from the back of the front blade to the back of the back blade. When the blade wears out, enter the new measurement for accurate calibration of the back blade.

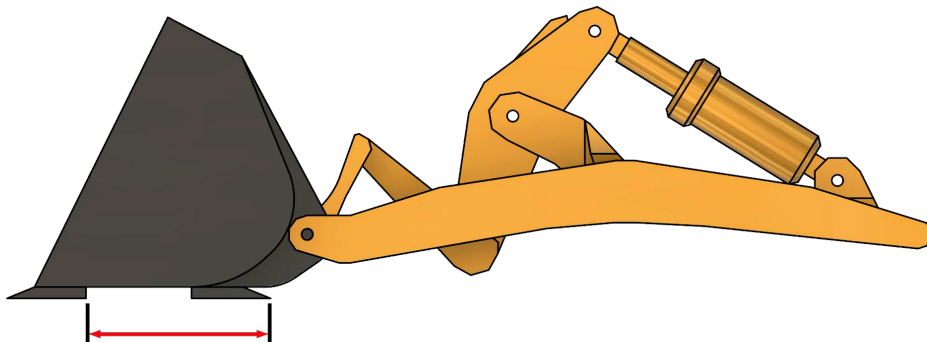

12.2.4. Flat angle

- 1) Place a spirit level underneath the cutting edge of the bucket. Move the bucket so the cutting edge lies horizontally.

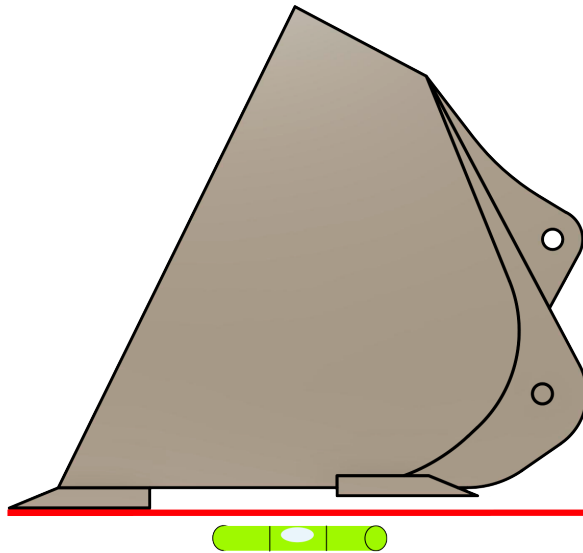

- 2) Press '**Reset**' if the bucket is horizontal.
- 3) Click on the check mark to confirm the offset and calibrated value.

12.2.5. Blade offset back

If there is a height difference between the front and back blades, enter the offset value for the back blade. The offset is the height difference between the blades.

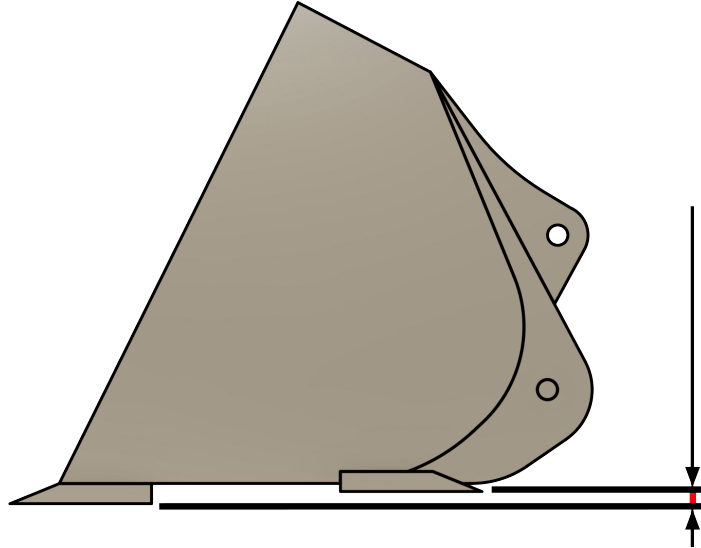

12.2.6. Depth

In the bucket calibration, tap '**Depth**' to enter the depth of the bucket. Measure the distance from the back of the front blade to the mount point. Tap the check mark to save.

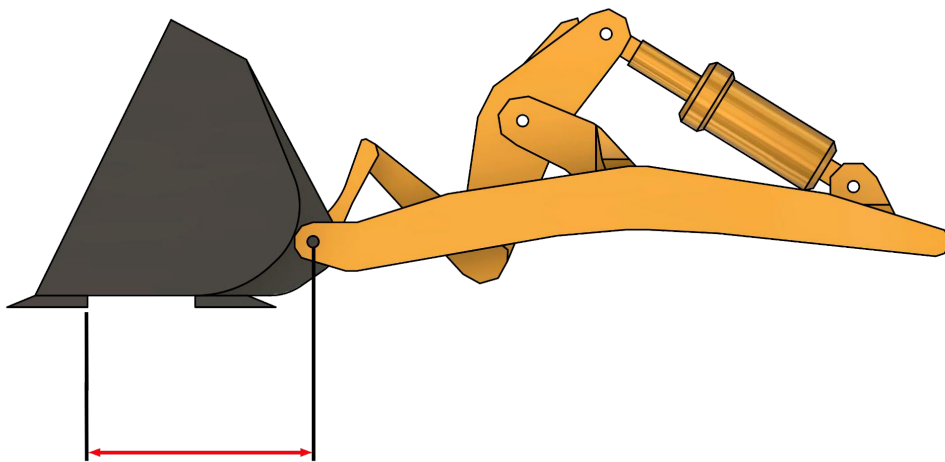

12.2.7. Width

Tap '**Width**' to enter the width of the bucket. The width is the total working width of the bucket, which you get by measuring the front blade. Tap the check mark to save.

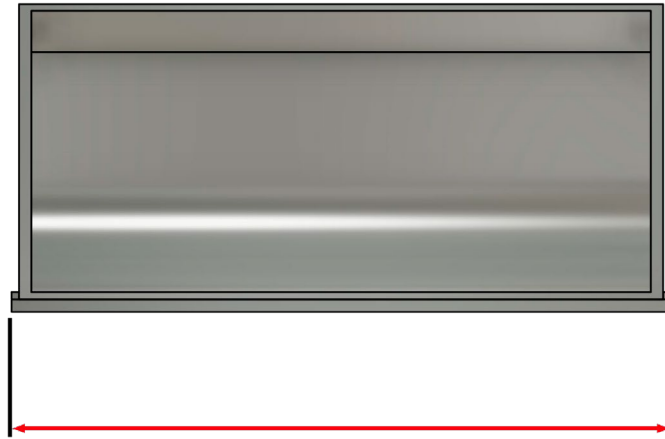

12.2.8. Mount height

In the bucket calibration, tap '**Mount height**' to enter the mount height. Measure the mount height, which is the distance from the bottom of the front blade to the bucket's mount point. Tap the check mark to save.

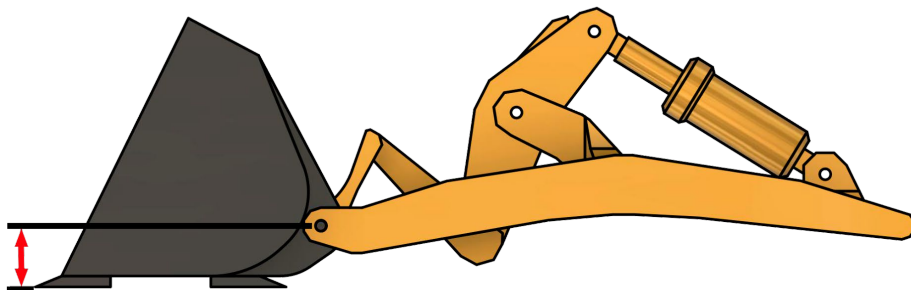

12.2.9. Height

Tap **'Height'** to enter the height of the bucket. The height is measured from the bottom of the front blade to the top of the bucket. Tap the check mark to save.

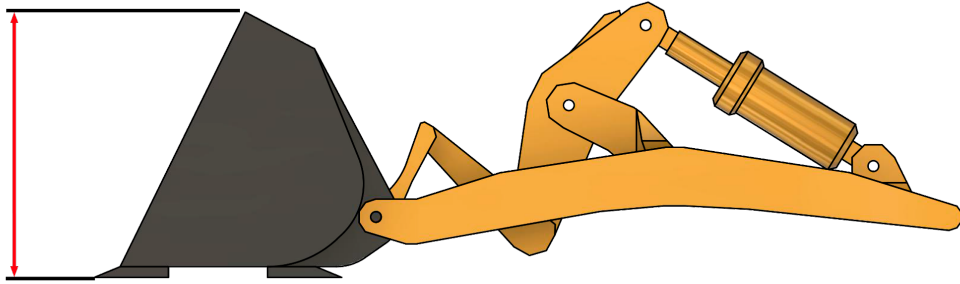

Please note that the software will not accept a height lower than the mount height. If the number entered is below the mount height, the calibration will not be completed. Pay special attention to this in cases where a different tool than a bucket, like a levelling beam, is connected to the Wheel Loader.

12.2.10. Coupler/Tilt

- 1) Tap '**Coupler/Tilt**' to state which application is present - i.e., None, Coupler/Tilt.

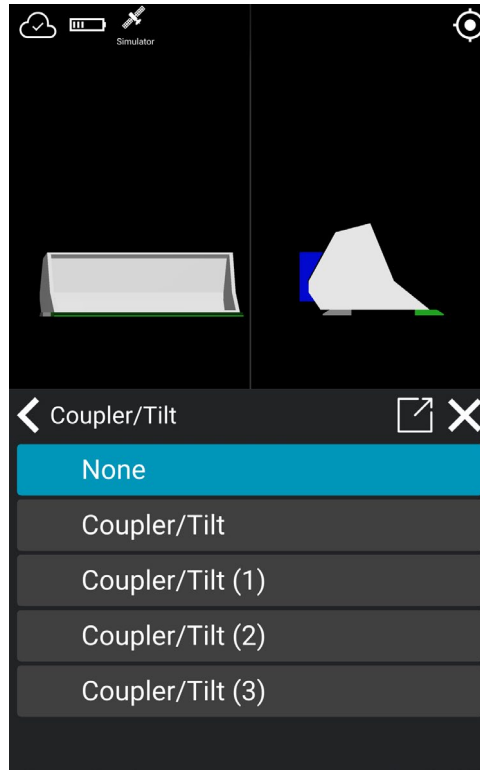

- 2) Tap '**Tilt offset**' if you have tilt installed. Tilt the bucket until the cutting edge is horizontal, using a spirit level. Then tap '**Reset**' and the check mark to save.

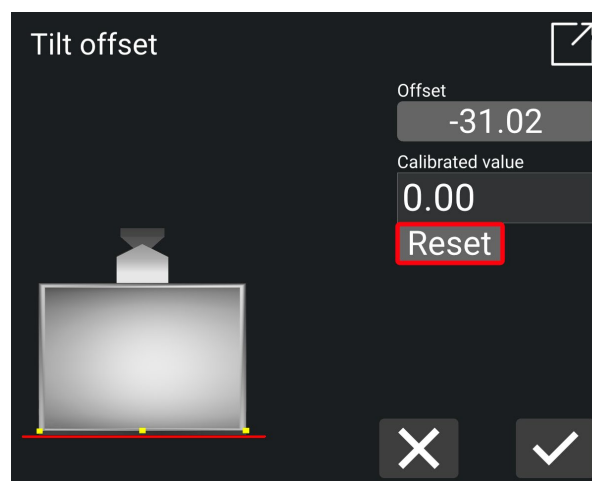

12.3. Check the calibration of your wheel loader

Before you start your daily work, we advise that a calibration check should be performed.

Also, ensure that the machine you are going to operate is fully calibrated and that your current bucket is calibrated. Follow these steps:

- 1) Place your tool point on a known point and verify the position.
- 2) Optionally place corner tool points on a known point one by one to verify the position.
- 3) If your reading is within the project's tolerances, your calibration is okay; otherwise, recalibrate.

12.4. Calibration backup

You can save a backup of the machine's current calibration file. If the same tablet is used on different machines, you can also save each machine's calibration as a separate backup, making it easy to access the correct file.

12.4.1. Snapshots

Every hour, the snapshot function automatically creates a backup file of the current calibration, or whenever changes are made to the calibration. Please note, however, that if multiple changes are made within the same hour, the previous file will be overwritten.

You can at any time change back to a previous calibration by selecting a backup file, as described in section 12.4.3: *Select Backup File*.

Please note that at the end of the day, the system automatically reviews the day's backup files and clears the list so that only the latest calibration remains available

12.4.2. Manual backups

To manually create a backup file, follow the description below.

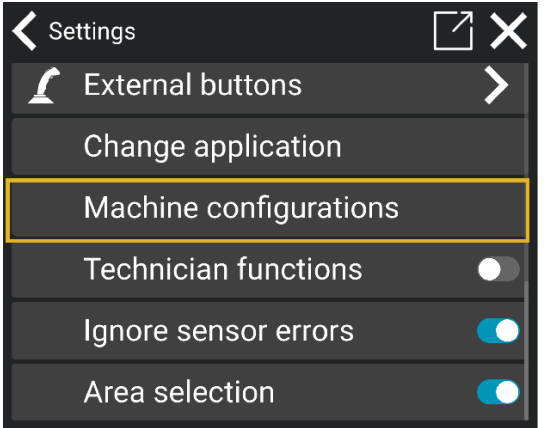
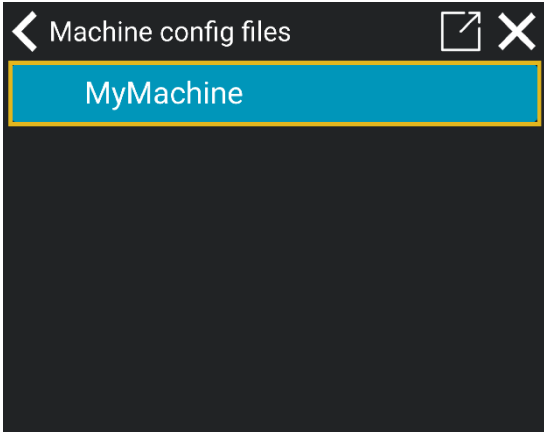
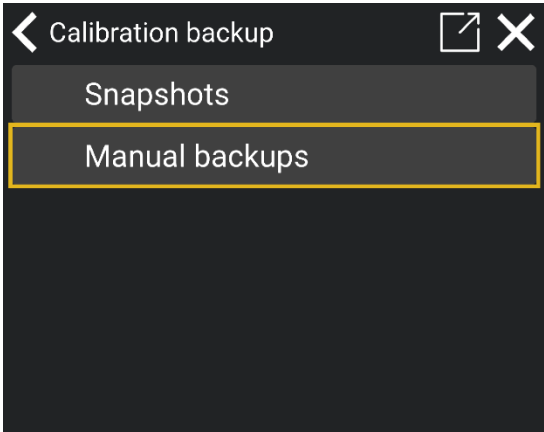
Step	Action	Illustration
1	Open <i>Machine configurations</i> in the <i>Settings menu</i> .	 <p>A screenshot of a settings menu. At the top is a back arrow and the text 'Settings', followed by a square icon and an 'X' icon. Below this is 'External buttons' with a right-pointing arrow. Underneath is 'Change application'. The 'Machine configurations' option is highlighted with a yellow border. Below it are 'Technician functions' with a grey toggle switch, 'Ignore sensor errors' with a blue toggle switch, and 'Area selection' with a blue toggle switch.</p>
2	Select <i>MyMachine</i> .	 <p>A screenshot of a menu titled 'Machine config files' with a back arrow and a close 'X' icon. The 'MyMachine' option is highlighted with a blue background and a yellow border.</p>
3	Select <i>Manual backups</i> .	 <p>A screenshot of a menu titled 'Calibration backup' with a back arrow and a close 'X' icon. The 'Manual backups' option is highlighted with a yellow border.</p>

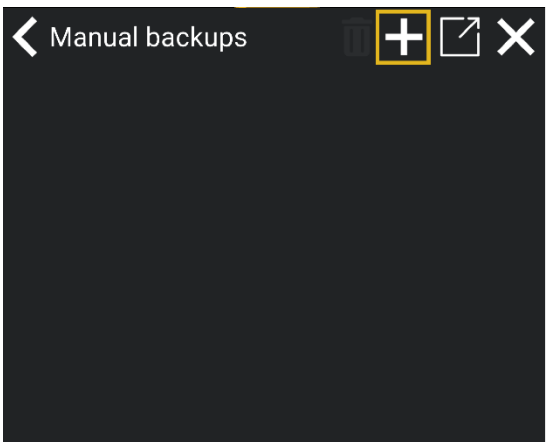
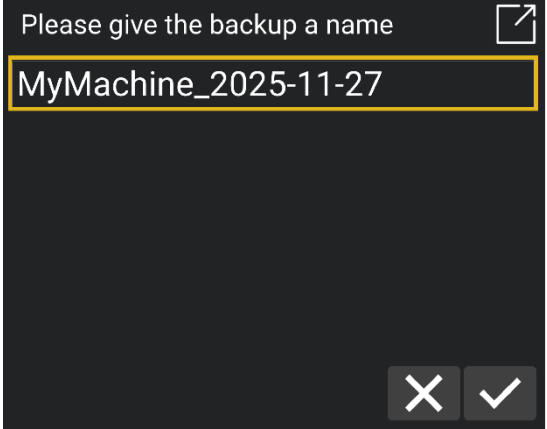
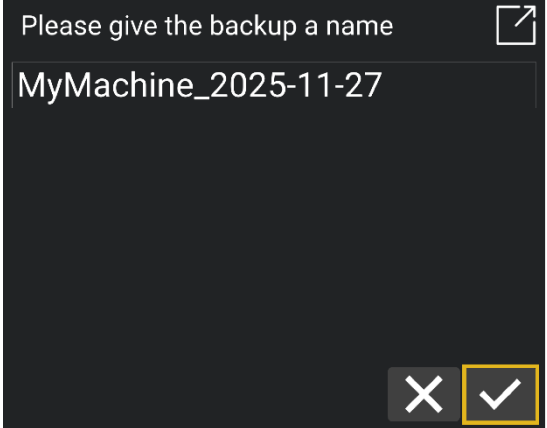
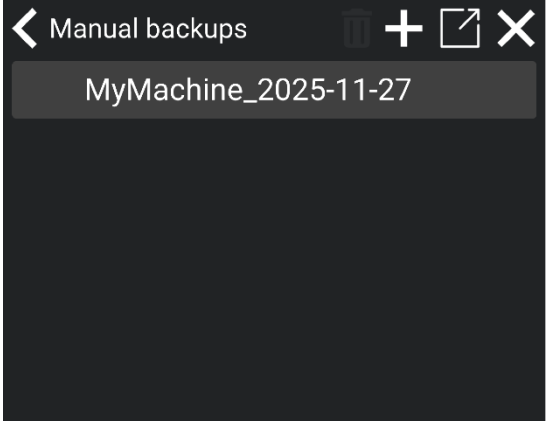
4	Tap the + icon to create a new backup.	
5	Give the backup a name.	
6	Save by tapping the check mark.	
NB!	The backup file will now be visible in the <i>Manual backups menu</i> .	

12.4.3. Select backup file

Please note that the procedure for selecting a backup file is the same for snapshots and manual backups.

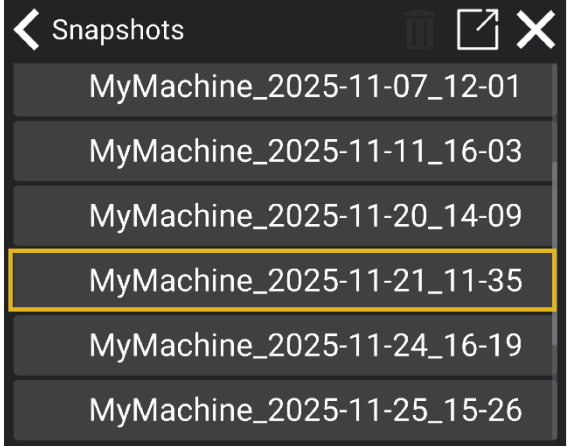
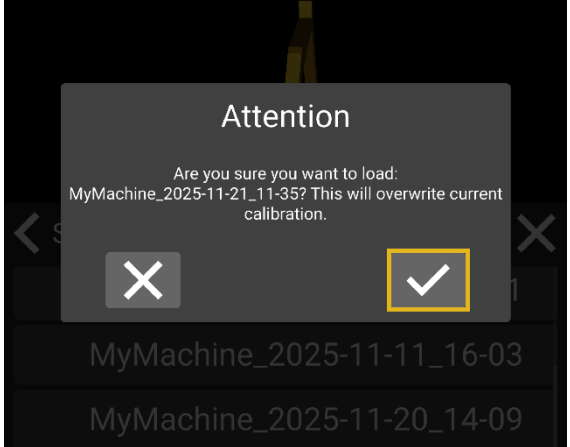
Step	Action	Illustration
1	Tap on the calibration file you want to apply to your system.	 <p>The screenshot shows a dark-themed interface titled 'Snapshots'. At the top, there is a back arrow, the title 'Snapshots', and icons for a share function and a close button. Below the title is a list of six backup files, each with a timestamp: 'MyMachine_2025-11-07_12-01', 'MyMachine_2025-11-11_16-03', 'MyMachine_2025-11-20_14-09', 'MyMachine_2025-11-21_11-35', 'MyMachine_2025-11-24_16-19', and 'MyMachine_2025-11-25_15-26'. The file 'MyMachine_2025-11-21_11-35' is highlighted with a yellow rectangular border.</p>
2	A notification appears on the screen. Tap on the check mark to confirm.	 <p>The screenshot shows an 'Attention' dialog box overlaid on the same 'Snapshots' list. The dialog box has a title 'Attention' and contains the text: 'Are you sure you want to load: MyMachine_2025-11-21_11-35? This will overwrite current calibration.' At the bottom of the dialog box are two buttons: a close button with an 'X' icon and a confirmation button with a checkmark icon. The checkmark button is highlighted with a yellow rectangular border.</p>

13. Troubleshooting

Error message	Possible cause	Possible Solution

If you cannot solve the problem using the advice found in the above table, contact your reseller.

14. Appendix

14.1. Software updates

When updating the Makin' 3D app to a new version, you might receive a notification from Google Play Protect. To proceed with the installation, allow Google Play Protect to scan the app. This ensures the new software version is safe to install.

- 1) Tap on '**Scan app**'.

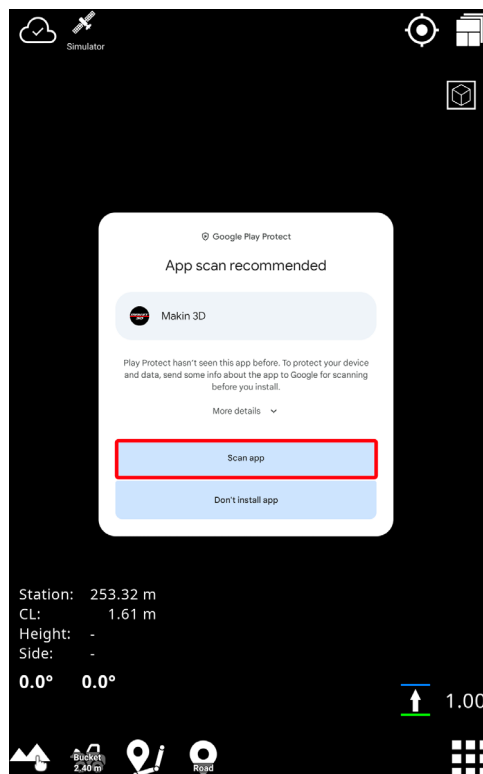

- 2) Tap '**Install**'.

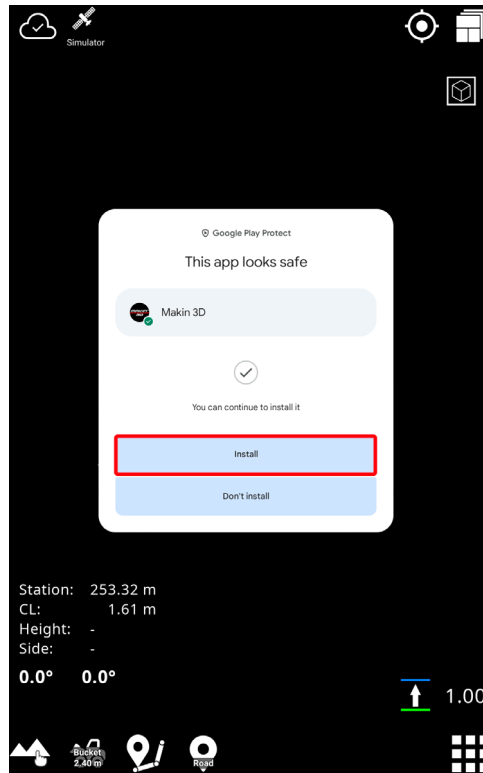

- 3) The Makin' 3D app is now updating to a new software version. Please wait while the update is installed.

14.2. GNSS limitations

Always take into consideration where your machine is located. Especially when the construction site is within city limits with tall buildings or other obstacles.

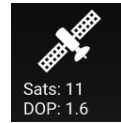

Also, if working near forest and mountain areas, interference could block the signal from one or more satellites and cause poor precision. Reflections could also occur.

Makin' 3D will inform you if there are not enough visible satellites or if your CQ/DOP is too high.

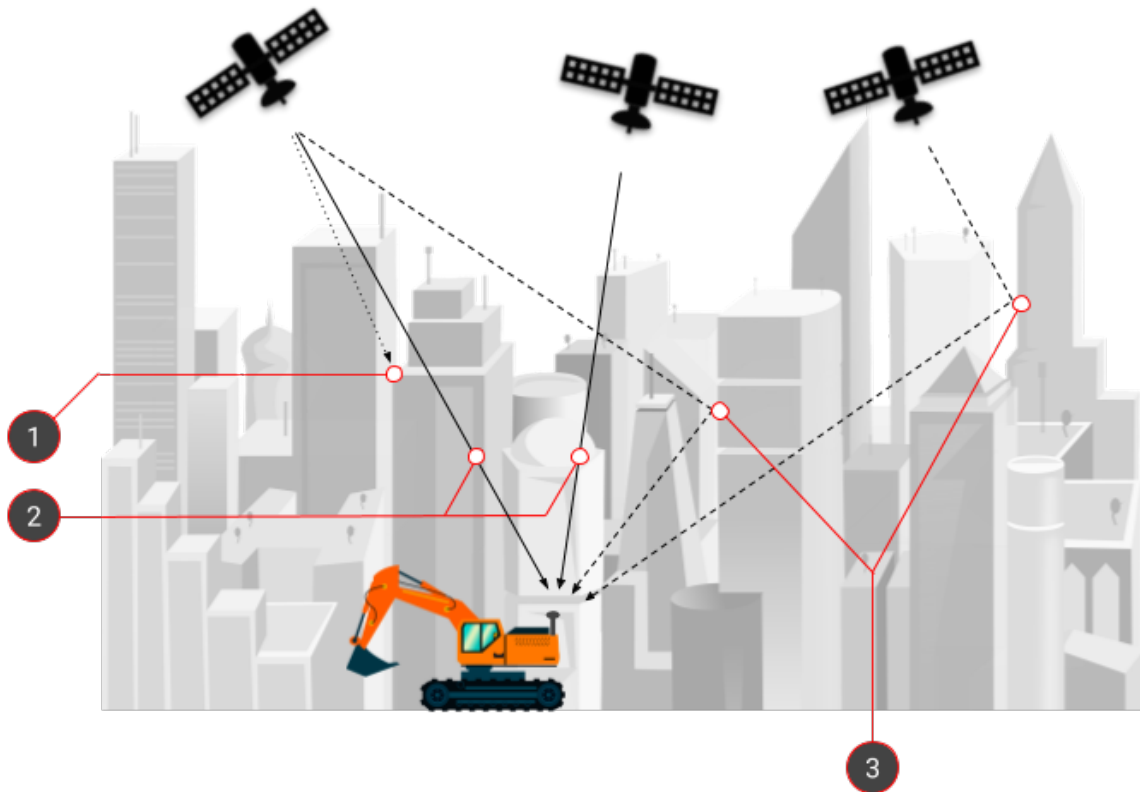

1. Direct signal blocked

3. Multipath errors

2. Direct signals perfectly received

14.3. Frequency

In situations where you have to specify the frequency according to a channel, refer to the table below for guidance. Channel 0 is the center frequency, and channels are distributed with a 25 kHz spacing (in this example).

Channel	Frequency (MHz)
0	446.6000
-1	446.5750
-4	446.5000
-5	446.4750

14.4. Compliance information

This product is intended to be mounted on earth-moving machinery exclusively for professional use, i.e. the product falls into the category: non-road vehicles exclusively for professional use. Makin hereby declares that the system and its components fulfill the requirements of the following EU directives applicable to this product category:

- 93/68/EEC - CE conformity marking
- 2014/53/EU - Radio Equipment Directive
- 2014/30/EU - EMC directive
 - DS/EN/ISO 13766-1:2018 - Earth-moving and building construction machinery – Electromagnetic compatibility (EMC) of machines with internal electrical power supply – Part 1: General EMC requirements under typical electromagnetic environmental conditions
 - DS/EN/ISO 13766-2:2018 - Earth-moving and building construction machinery – Electromagnetic compatibility (EMC) of machines with internal electrical power supply – Part 2: Additional EMC requirements for functional safety

The respective product category falls outside the scope of these directives:

- 2011/65/EU - RoHS
- 2012/19/EU - WEEE

14.5. Tablet connections

14.5.1. Tablet Panasonic FZ-A3 connections

The Panasonic FZ-A3 has connectors located in four places: on the top, on the side, inside the battery compartment, and at the bottom.

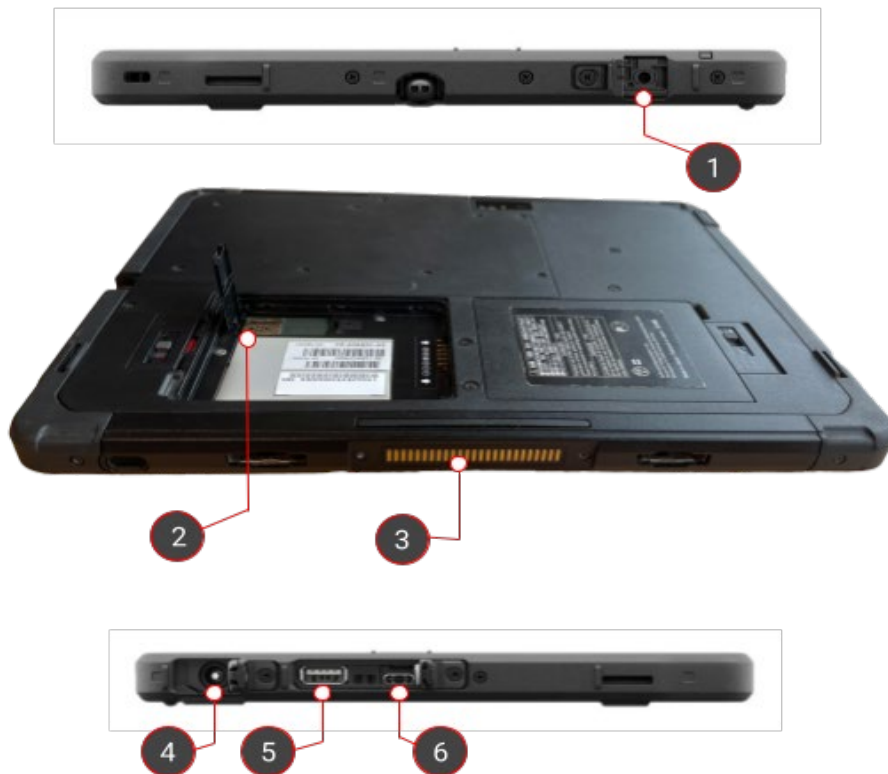

1. Mini-jack audio output

2. Micro SIM card for broadband internet on both tablet and GNSS receiver

3. Docking station connector for data and power transmission

4. 16 V DC input power for external charger

5. USB-A

6. USB-C

14.5.2. Tablet Panasonic FZ-A2 connections

The Panasonic FZ-A2 has connectors on the top, on the side, inside the battery compartment, and at the bottom.

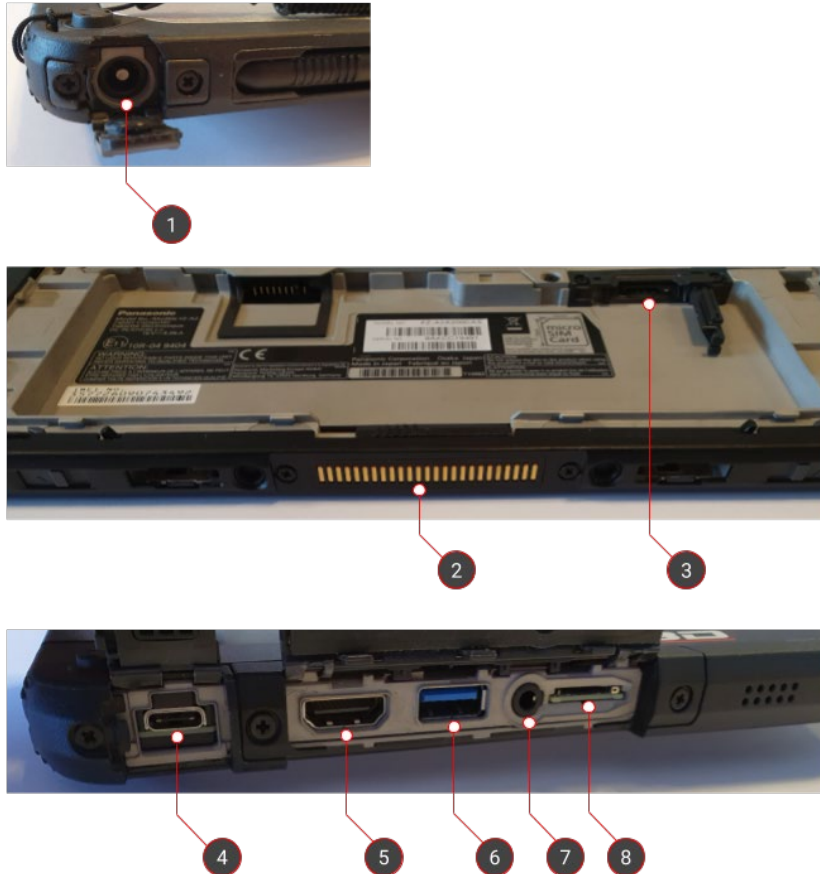

1. 16 V DC input power for external charger

2. Docking station connector for data and power transmission

3. Micro SIM card for broadband internet on both tablet and GNSS receiver

4. USB-C

5. HDMI output to external screen

6. SuperSpeed USB-A 3.0

7. Mini-jack audio output

8. Micro SD for extended storage

14.6. Docking station connections

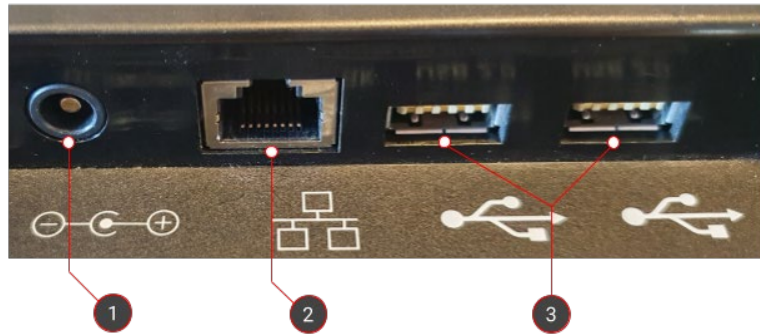

1. 16 V DC input power for external charger

3. 2x HighSpeed USB-A 2.0

2. RJ-45 Ethernet

14.7. Tablet set-up

14.7.1. Tablet buttons and light indicators (Panasonic FZ-A2)



1. On/Off button
2. Power indicator
 - *No light*: System is off
 - *Green light*: System is on
 - *Blinking green light*: Tablet in sleep mode
3. Charging indicator
 - *No light*: External power source not connected
 - *Red light*: Battery power is critically low. External power source is not connected.
 - *Orange light*: Tablet is currently charging
 - *Green light*: Tablet fully charged
4. Auto-rotate screen. The button can be programmed (more info below).
5. Volume up
6. Volume down
7. Not in use. The button can be programmed (See section 14.7.2. below).
8. Not in use. The button can be programmed (See section 14.7.2. below).
9. Basic tablet functionality via the 'Dashboard' app. The button can be programmed (See section 14.7.2. below).

14.7.2. Programming the physical tablet buttons (Panasonic FZ)

The Panasonic tablet has three user-programmable function keys, A1, A2, and A3. You can assign Makin' 3D functions to these keys.

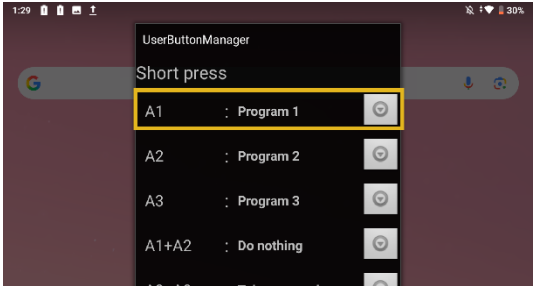
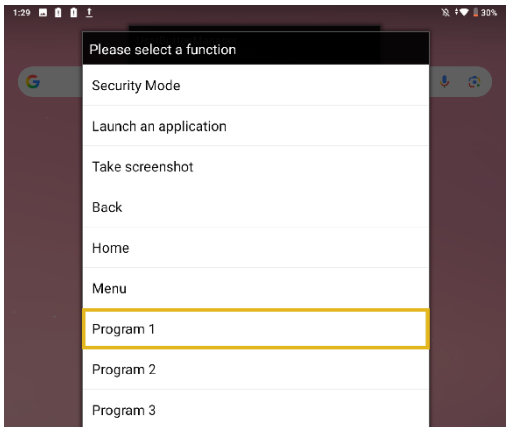
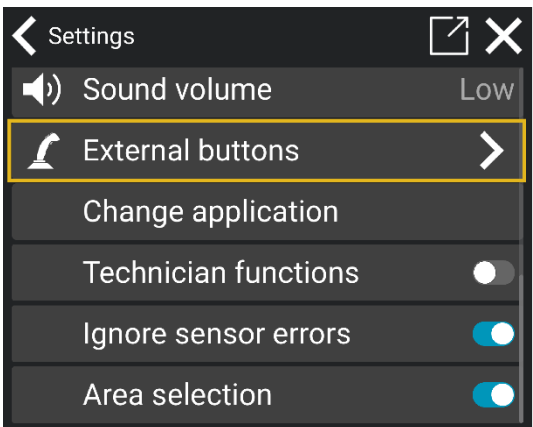
Step	Action	Illustration
1	Open the app <i>UserButtonManager</i> .	
2	Select the physical button to which you want to assign the Makin' 3D function (A1, A2 or A3).	
3	When clicked, a pop-up window will open. Select the desired function – it will be labelled <i>Program 1</i> , <i>Program 2</i> or <i>Program 3</i> depending on the button you select in the Makin' 3D app.	
4	Go to the <i>Settings menu</i> in the Makin' 3D app.	
5	Open the <i>External Buttons</i> menu.	

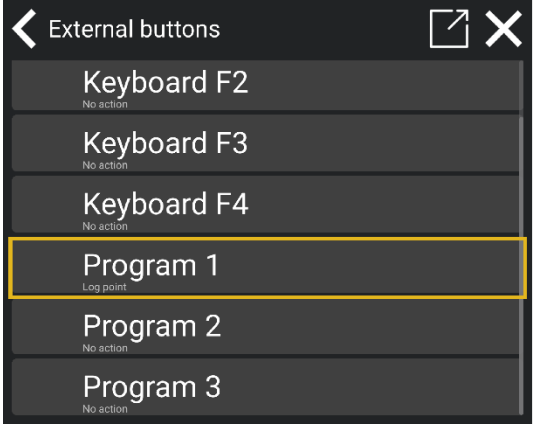
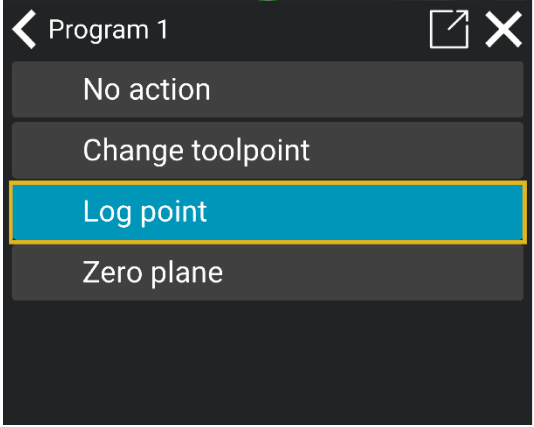
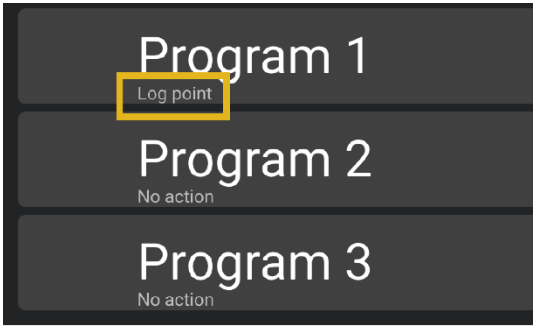
<p>6</p>	<p>Click the button you want to program (<i>Program 1, Program 2 or Program 3</i>).</p> <p>Note: If the button does not appear on the list, press the physical button, this will add the option to the list.</p>	
<p>7</p>	<p>Select the function you want to assign to the button.</p>	
<p>8</p>	<p>Check that the function has been assigned to the button. The function appears beneath the button name. If a button has not been programmed, it will show the description <i>No action</i>.</p>	

14.8. Interface Box (IB-1)

Status information on the interface module can be read out by watching the LED just next to the power connector.

Color	Indication
Green	ON - all ok
Flashing red	Firmware issue - contact reseller
White	System check of software
Blue	Updates to software are ongoing

14.9. Demo mode

You can use your Makin' 3D system on Windows in demo mode to gain confidence in the user interface.

Please find below the shortcuts for the functions.

Keyboard	Action
←	Rotate camera left
→	Rotate camera right
↓	Tilt camera down
↑	Tilt camera up
Space	Start/stop automatic driving
+	Raise machine model
-	Lower machine model
.	Change view (sampling through options)
b	Rotate model left
Shift b / B	Rotate model right
m	Rotate model right
Shift m / M	Rotate model left
n	Drive forward (in direction of cab orientation)
Shift n / N	Drive backwards (in direction of cab orientation)
s	Drive forward along pre-determined line (centreline)
Shift s / S	Drive backwards along pre-determined line (centreline)

j	Jump around close to the project
Shift j /J	Jumps to the roundabout in Odense S
u	Jump to current side reference
p	Opens the Plan menu
o	Opens the offset menu
g	Opens the jog window
w	Activate/deactivate wireframe mode
r	Refresh / Finds the model
R	Reload / reset model orientation (undoes number key modifications)
1	Tilt model to the left (Roll)
Alt 1	Tilt model to the right (Roll)
2	Tilt model forward (Pitch)
Alt 2	Tilt model backwards (Pitch)
3 / 4 / 5 / 6 / 7 / 8 / 9	Move a machine part – follow the machine from the boom outwards to the bucket. The connection between the key and the machine part depends on the machine's configuration.
Alt 3 / 4 / 5 / 6 / 7 / 8 / 9	Reverses the movement

14.10. Xbox controller

You can use an Xbox controller to control the machine model in the Makin' 3D app on your tablet. It is an easy way to gain confidence in the user interface. This feature is only available when you connect the Xbox controller to a Panasonic FZ-A3 tablet.

How to connect the Xbox controller to your tablet:

1. Go to *Settings* on your tablet.
2. Click on *Connected devices*.
3. Press the connect button on the Xbox controller. The button is located on top of the controller (Number 4 on the image below).
4. Click on *Pair new device*.
5. Click on the available Xbox Wireless Controller on the tablet screen. Wait for the devices to pair.
6. Your Xbox controller is now connected to the tablet and ready for use.

Please note:

The available functions depend on the machine model activated on the tablet. Use the table below to see the button functions for this model.

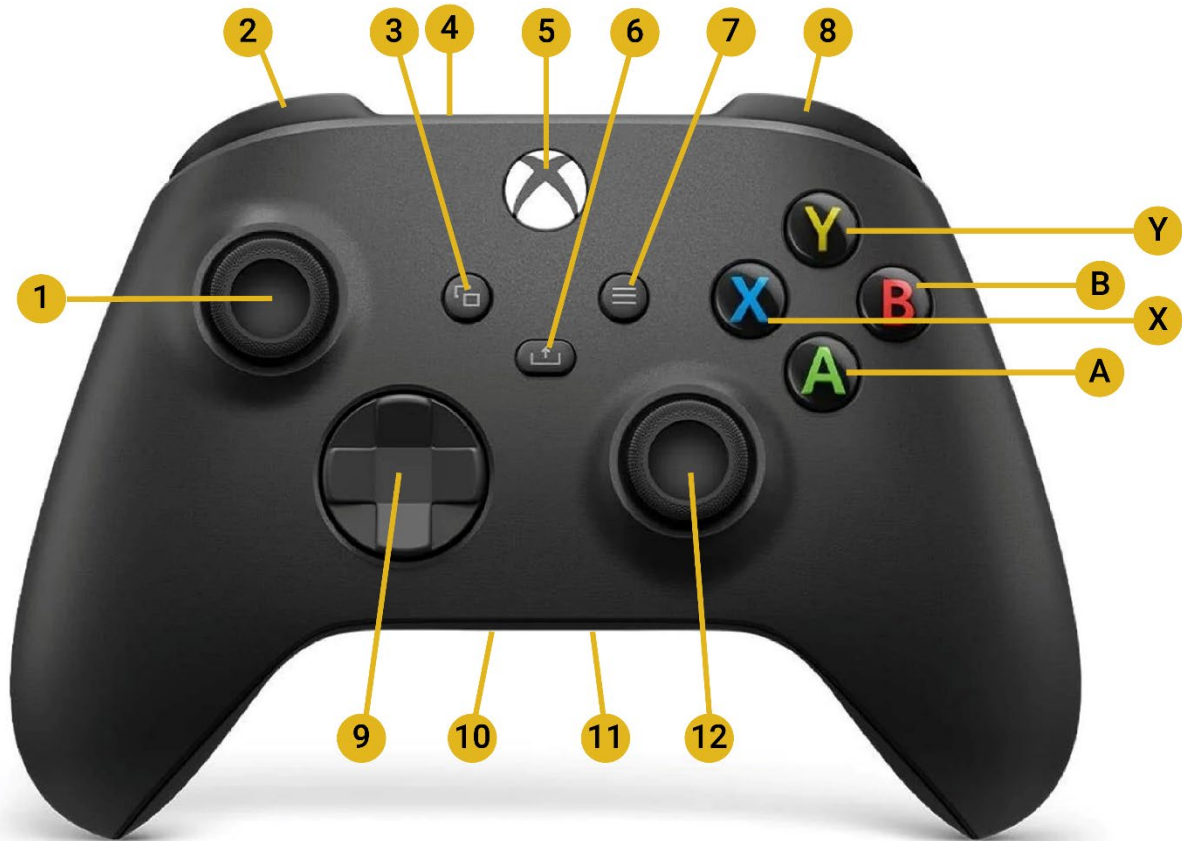

Button direction	Dig mode	Drive mode
1 Press down	Switch to drive mode	Switch to dig mode
1 Forward	Arm out	Drive forward
1 Backwards	Arm in	Drive backwards
1 left	Swing left	Turn machine left
1 right	Swing right	Turn machine right
2	Tilt left	Decrease turbo (stepwise)
3	-	-
4	Connect controller	

5	Power on/off	
6	Jump to side reference	
7	-	-
8	Tilt right	Increase turbo (stepwise)
9	-	-
10	-	-
11	-	-
12 forward	Boom down	Pitch machine down
12 backwards	Boom up	Pitch machine up
12 left	Close bucket	Roll machine left
12 right	Open bucket	Roll machine right
A	Move machine down to 1 meter	
B	Rotate bucket right	
X	Rotate bucket left	
Y	Move machine up 1 meter	